

Sponsored by:



Structured Cabling Supplement

Cisco Networking Academy Program

CCNA 1: Networking Basics v3.1

Objectives

The Structured Cabling Supplement for CCNA provides curriculum and laboratory exercises in seven areas:

- a. Structured Cabling Systems
- b. Structured Cabling Standards and Codes
- c. Safety
- d. Tools of the Trade
- e. Installation Process
- f. Finish Phase
- g. The Cabling Business

This material and the associated labs provide a broad introduction to structured cabling installation.

The section on Structured Cabling Systems discusses the rules and subsystems of structured cabling for a local-area network (LAN). A LAN is defined as a single building or group of buildings in a campus environment in close proximity to one another, typically less than two square kilometers or one square mile. This supplement starts at the demarcation point, works through the various equipment rooms, and continues to the work area. The issue of scalability is also addressed.

The learning objectives for Structured Cabling Systems are as follows:

- 1.1 Rules of Structured Cabling for LANs
- 1.2 Subsystems of Structured Cabling
- 1.3 Scalability
- 1.4 Demarcation Point
- 1.5 Telecommunications and Equipment Rooms
- 1.6 Work Areas
- 1.7 MC, IC, and HC

The section on Structured Cabling Standards and Codes introduces the standards-setting organizations that establish the guidelines used by cabling specialists. Important information about these international standards organizations is included.

The learning objectives for Structured Cabling Systems and Codes are as follows:

- 2.1 Telecommunications Industry Association (TIA) and Electronic Industries Association (EIA)
- 2.2 European Committee for Electrotechnical Standardization (CENELEC)
- 2.3 International Organization for Standardization (ISO)
- 2.4 Codes for the United States
- 2.5 Evolution of Standards

The Safety section contains important information that is often overlooked when discussing low voltage telecommunications wiring. Students that are not accustomed to working in the physical workplace will benefit from the labs and training in this section.

The learning objectives for Safety are as follows:

- 3.1 Safety Codes and Standards for the United States
- 3.2 Safety Around Electricity
- 3.3 Lab and Workplace Safety Practices
- 3.4 Personal Safety Equipment

The Tools of the Trade section discusses how various tools can help turn a difficult job with ordinary results into a simple job with outstanding results. This module gives students hands-on experience using several of the tools that telecommunications cabling installers rely on for professional results.

The learning objectives for Tools of the Trade are as follows:

- 4.1 Stripping and Cutting Tools
- 4.2 Termination Tools
- 4.3 Diagnostic Tools
- 4.4 Installation Support Tools

The Installation Process section describes the elements of an installation. This chapter begins with the rough-in phase, when the cables are pulled into place. This section also discusses riser or backbone cables, the fire-stops used when a wire passes through a fire rated wall, copper terminations, and fixtures such as wall adapters.

The learning objectives for Installation Process are as follows:

- 5.1 Rough-In Phase
- 5.2 Vertical Backbone and Horizontal Cable Installation
- 5.3 Fire-Stops
- 5.4 Terminating Copper Media
- 5.5 The Trim Out Phase

The Finish Phase section discusses the point at which installers test and sometimes certify their work. Testing ensures that all the wires route to their appointed destination. Certification ensures that the quality of the wiring and connection meet industry standards.

The learning objectives for Finish Phase are as follows:

- 6.1 Cable Testing
- 6.2 Time Domain Reflectometer (TDR)
- 6.3 Cable Certification and Documentation
- 6.4 Cutting Over

The Cabling Business section discusses the business side of the industry. Before cables can be installed, there must be a bid. Before there can be a bid, there must be a request for a proposal, and several meetings and walk-throughs to determine the scope of the work. Documentation may be required to describe the project and show how it was built. Licenses and union membership may also be required to perform the work. All projects must be performed in a timely manner with minimal waste of materials. This usually requires project planning and program management applications.

The learning objectives for The Cabling Business are as follows:

- 7.1 Site Survey
- 7.2 Labor Situations
- 7.3 Contract Revision and Signing
- 7.4 Project Planning
- 7.5 Final Documentation

Lab exercises give students the opportunity to practice the manual skills portion of structured cabling installation.

1 Structured Cabling Systems

1.1 Rules of Structured Cabling for LANs

Structured cabling is a systematic approach to cabling. It is a method for creating an organized cabling system that can be easily understood by installers, network administrators, and any other technicians that deal with cables.

There are three rules that will help ensure the effectiveness and efficiency of structured cabling design projects.

The first rule is to look for a complete connectivity solution. An optimal solution for network connectivity includes all the systems that are designed to connect, route, manage, and identify cables in structured cabling systems. A standards-based implementation is designed to support both current and future technologies. Following the standards will help ensure the long-term performance and reliability of the project.

The second rule is to plan for future growth. The number of cables installed should also meet future requirements. Category 5e, Category 6, and fiber-optic solutions should be considered to ensure that future needs will be met. The physical layer installation plan should be capable of functioning for ten or more years.

The final rule is to maintain freedom of choice in vendors. Even though a closed and proprietary system may be less expensive initially, this could end up being much more costly over the long term. A non-standard system from a single vendor may make it more difficult to make moves, adds, or changes at a later time.

1.2 Subsystems of Structured Cabling

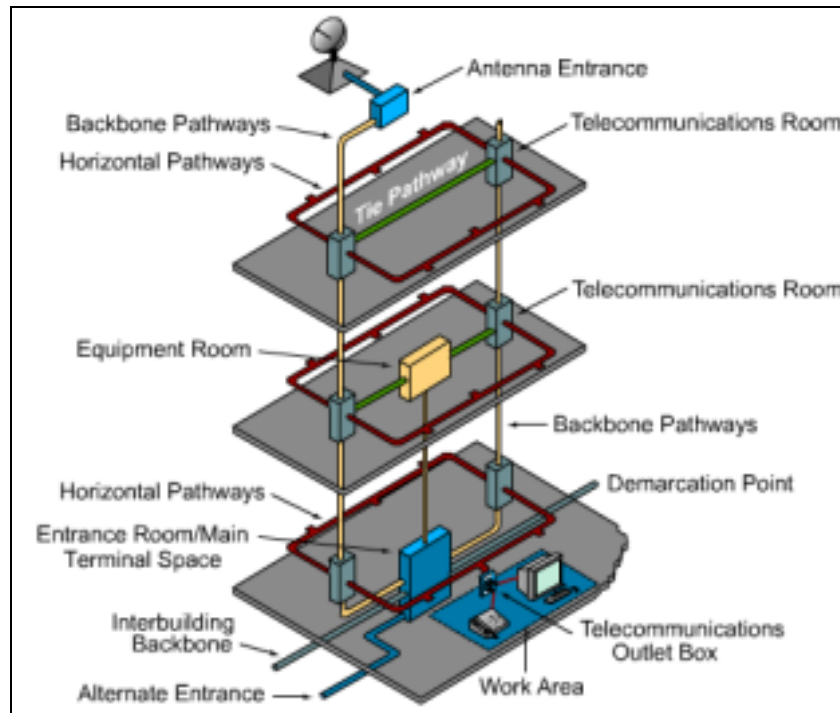

Figure 1 Subsystems of Structured Cabling

There are seven subsystems associated with the structured cabling system, as shown in Figure 1. Each subsystem performs certain functions to provide voice and data services throughout the cable plant:

- Demarcation point (demarc) within the entrance facility (EF) in the equipment room
- Equipment room (ER)
- Telecommunications room (TR)
- Backbone cabling, which is also known as vertical cabling
- Distribution cabling, which is also known as horizontal cabling
- Work area (WA)
- Administration

The demarc is where the outside service provider cables connect to the customer cables in the facility. Backbone cabling is the feeder cables that are routed from the demarc to the equipment rooms and then on to the telecommunications rooms throughout the facility. Horizontal cabling distributes cables from the telecommunication rooms to the work areas. The telecommunications rooms are where

connections take place to provide a transition between the backbone cabling and horizontal cabling.

These subsystems make structured cabling a distributed architecture with management capabilities that are limited to the active equipment, such as PCs, switches, hubs, and so forth. Designing a structured cabling infrastructure that properly routes, protects, identifies, and terminates the copper or fiber media is absolutely critical for network performance and future upgrades.

1.3 Scalability

A LAN that can accommodate future growth is referred to as a scalable network. It is important to plan ahead when estimating the number of cable runs and cable drops in a work area. It is better to install extra cables than to not have enough.

In addition to pulling extra cables in the backbone area for future growth, an extra cable is generally pulled to each workstation or desktop. This gives protection against pairs that may fail on voice cables during installation, and it also provides for expansion. It is also a good idea to provide a pull string when installing the cables to make it easier for adding cables in the future. Whenever new cables are added, a new pull string should also be added.

1.3.1 Backbone scalability

When deciding how much extra copper cable to pull, first determine the number of runs that are currently needed and then add approximately 20 percent of extra cable.

A different way to obtain this reserve capability is to use fiber-optic cabling and equipment in the building backbone. For example, the termination equipment can be updated by inserting faster lasers and drivers to accommodate fiber growth.

1.3.2 Work area scalability



Figure 1 Allow for Growth

Each work area needs one cable for voice and one for data. However, other devices may need a connection to either the voice or the data system. Network printers, FAX machines, laptops, and other users in the work area may all require their own network cable drops.

After the cables are in place, use multiport wall plates over the jacks. There are many possible configurations for modular furniture or partition walls. Color-coded jacks can be used to simplify the identification of circuit types, as shown in Figure 1. Administration standards require that every circuit should be clearly labeled to assist in connections and troubleshooting.

A new technology that is becoming popular is Voice over Internet Protocol (VoIP). This technology allows special telephones to use data networks when placing telephone calls. A significant advantage of this technology is the avoidance of costly long distance charges when VoIP is used over existing network connections. Other devices like printers or computers can be plugged into the IP phone. The IP phone then becomes a hub or switch for the work area. Even if these types of connections are planned, enough cables should be installed to allow for growth. Especially consider that IP telephony and IP video traffic may share the network cables in the future.

To accommodate the changing needs of users in offices, it is recommended to provide at least one spare cable to the work area

outlet. Offices may change from single user to multiuser spaces. This can result in an inefficient work area if only one set of communication cables was pulled. Assume that every work area will accommodate multiple users in the future.

1.4 Demarcation Point

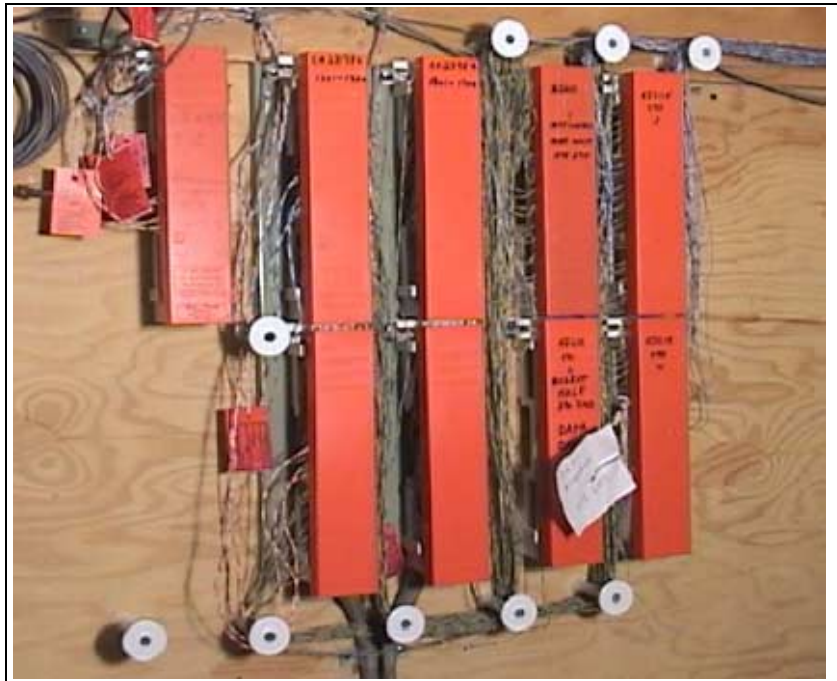

Figure 1 Demarcation Point

The demarcation point (demarc), shown in Figure 1, is the point at which outdoor cabling from the service provider connects to the intrabuilding backbone cabling. It represents the boundary between the responsibility of the service provider and the responsibility of the customer. In many buildings, the demarc is near the point of presence (POP) for other utilities such as electricity and water.

The service provider is responsible for everything from the demarc out to the service provider facility. Everything from the demarc into the building is the responsibility of the customer.

The local telephone carrier is typically required to terminate cabling within 15 m (49.2 feet) of building penetration and to provide primary voltage protection. The service provider usually installs this.

The Telecommunications Industry Association (TIA) and Electronic Industries Alliance (EIA) develop and publish standards for many industries, including the cabling industry. To ensure that the cabling is safe, installed correctly, and retains performance ratings, these standards should be followed during any voice or data cabling installation or maintenance.

The TIA/EIA-569-A standard specifies the requirements for the demarc space. The standards for the structure and size of the demarc space are based on the size of the building. In buildings larger than 2,000 square meters (21,528 sq ft), a locked, dedicated, and enclosed room is recommended.

The following are general guidelines for setting up a demarcation point space:

- Allow 1 square meter (10.8 sq feet) of plywood wall mount for each 20-square meter (215.3-sq feet) area of floor space
- Cover the surfaces where the distribution hardware is mounted with fire-rated plywood or plywood that is painted with two coats of fire retardant paint
- Either the plywood or the covers for the termination equipment should be colored orange to indicate the point of demarcation.

1.5 Telecommunications and Equipment Rooms



Figure 1 Telecommunications Room



Figure 2 Panduit Distribution Rack

After the cable enters the building through the demarc, it travels to the entrance facility (EF), which is usually in the equipment room (ER). The equipment room is the center of the voice and data network. An equipment room is essentially a large telecommunications room that may house the main distribution frame, network servers, routers, switches, the telephone PBX, secondary voltage protection, satellite receivers, modulators, high speed Internet equipment, and so on. The design aspects of the equipment room are specified in the TIA/EIA-569-A standard.

In larger facilities, the equipment room may feed one or more telecommunications rooms (TR) that are distributed throughout the building. The TRs contain the telecommunications cabling system equipment for a particular area of the LAN such as a floor or part of a floor, as shown in Figure 1. This includes the mechanical terminations and cross-connect devices for the horizontal and backbone cabling system. Departmental or workgroup switches, hubs, and routers are commonly located in the TR.

A wiring hub and patch panel in a TR may be mounted to a wall with a hinged wall bracket, a full equipment cabinet, or a distribution rack as shown in Figure 1.

A hinged wall bracket must be attached to the plywood panel so that it covers the underlying wall surface. The hinge allows the assembly

to swing out so that technicians can easily access the backside of the wall. It is important to allow 48 cm (19 inches) for the panel to swing out from the wall.

A distribution rack must have a minimum of 1 meter (3 feet) of workspace clearance in the front and rear of the rack. A 55.9-cm (22-inch) floor plate is used to mount the distribution rack. The floor plate will provide stability and determine the minimum distance for the final position of the distribution rack. A distribution rack is shown in Figure 2.

A full equipment cabinet requires at least 76.2 cm (30 inches) of clearance in front for the door to swing open. Equipment cabinets are generally 1.8-m (5.9-feet) high, 0.74-m (2.4-feet) wide, and 0.66-m (2.16-feet) deep.

When placing equipment into equipment racks, consider whether or not the equipment uses electricity. Other considerations include cable routing, cable management, and ease of use. For example, a patch panel should not be placed high on a rack if a significant number of changes will occur after the installation. Heavier equipment such as switches and servers should be placed near the bottom of the rack for stability.

Scalability that allows for future growth is another consideration in an equipment layout. The initial layout should include extra rack space for future patch panels or extra floor space for future rack installations.

Proper installation of equipment racks and patch panels in the TR will allow for easy modifications to the cabling installation in the future.

1.6 Work Areas

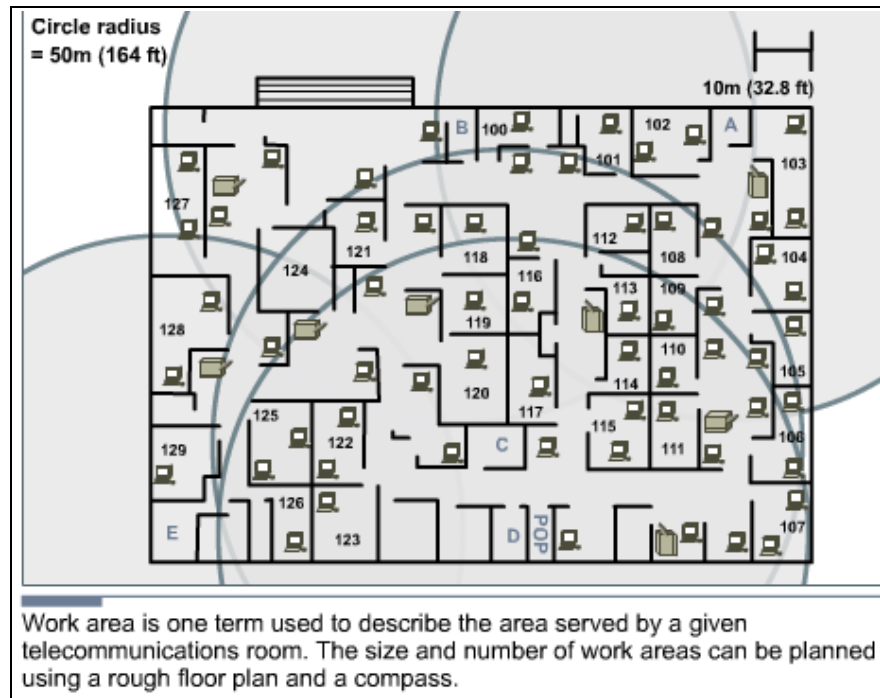

Figure 1 Work Areas

A work area is the area serviced by an individual TR. A work area usually occupies one floor or part of one floor of a building, as shown in Figure 1.

The maximum distance for a cable from the termination point in the TR to the termination at the work area outlet must not exceed 90 meters (295 feet). This 90 meter maximum horizontal cabling distance is referred to as the permanent link. Each work area must have at least two cables. One for data and the other for voice. As previously discussed, accommodations for other services and future expansion must also be considered.

Because most cables cannot be strung across the floor, cables are usually contained in wire management devices such as trays, baskets, ladders, and raceways. Many of these devices will route the paths of the wires in the plenum areas above suspended ceilings. The ceiling height must then be multiplied by two and subtracted from the maximum work area radius to allow for wiring to and from the wire management device.

ANSI/TIA/EIA-568-B specifies that there can be 5 m (16.4 feet) of patch cord to interconnect equipment patch panels, and 5 m (16.4 feet) of cable from the cable termination point on the wall to the telephone or computer. This additional maximum of 10 meters (33 feet) of patch cords added to the permanent link is referred to as the horizontal channel. The maximum distance for a channel is 100

meters (328 feet), the 90-meter (295 feet) maximum permanent link plus 10 meters (33 feet) maximum of patch cords.

Other factors may decrease the work area radius. For example, the cable routes may not lead straight to the destination. The location of heating, ventilation, and air conditioning equipment, power transformers and lighting equipment may dictate paths that add length. After everything is taken into account, a maximum radius of 100 m (328 feet) may be closer to 60 m (197 feet). A work area radius of 50 m (164 feet) is commonly used for design purposes.

1.6.1 Servicing the work area

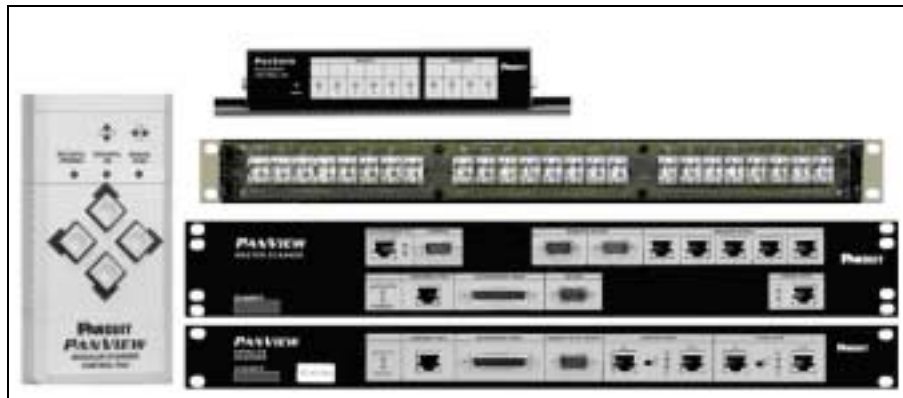

Figure 1 Servicing the Work Areas

Patching is helpful when connectivity changes occur frequently. It is much easier to patch a cable from the work area outlet to a new position in the TR than it is to remove terminated wires from connected hardware and reterminate them to another circuit. Patch cords are also used to connect networking equipment to the cross-connects in a TR. Patch cords are limited by the TIA/EIA-568-B.1 standard to 5 m (16.4 feet).

A uniform wiring scheme must be used throughout a patch panel system. For example, if the T568A wiring plan is used to terminate information outlets or jacks, the T568A scheme should be used to terminate patch panels as well. The same is true for the T568B wiring scheme.

Patch panels can be used for Unshielded Twisted Pair (UTP), Screened Twisted Pair (ScTP), or, if mounted in enclosures, fiber-optic connections. The most common patch panels are for UTP. These patch panels use RJ-45 jacks. Patch cords, usually made with stranded cable to increase flexibility, connect to these plugs.

In most facilities, there is no provision to keep authorized maintenance personnel from installing unauthorized patches or installing an unauthorized hub into a circuit. There is an emerging family of automated patch panels which can provide extensive network monitoring in addition to simplifying the provisioning of

moves, adds, and changes. These patch panels normally provide an indicator lamp over any patch cord that needs to be removed, and then once the cord is released, provides a second light over the jack to which they should be reattached. In this way the system can automatically guide a relatively unskilled employee through moves, adds, and changes.

The same mechanism that detects when the operator has moved a given jack will also detect when a jack has been pulled. An unauthorized resetting of a patch can trigger an event in the system log, and if need be trigger an alarm. For instance, if a half-dozen wires to the work area suddenly show up as being open at 2:30 in the morning, this is an event worth looking into, as theft may be occurring.

1.6.2 Types of patch cables



Figure 1 UTP Patch Cable

Patch cables come in a variety of wiring schemes. The straight-through cable is the most common patch cable. It has the same wiring scheme on both ends of the cable. Therefore, a pin on one end is connected to the corresponding pin number on the other end. These types of cables are used to connect PCs to a network, a hub, or a switch.

When connecting a communications device such as a hub or switch to an adjacent hub or switch, a crossover cable is typically used. Crossover cables use the T568A wiring plan on one end and T568B on the other end.

[Lab 1: Examination of Termination Types](#)

1.6.3 Cable management



Figure 1 Panduit Rack-Mounted Vertical and Horizontal Cable Management System

Cable management devices are used to route cables along a neat and orderly path and to assure minimum bend radius is maintained. Cable management also simplifies cable additions and modification to the wiring system.

There are many options for cable management in a TR. Cable baskets can be used for easy, lightweight installations. Ladder racks are often used to support heavy loads of bundled cable. Different types of conduits can be used to run cable inside walls, ceilings, floors, or to shield them from external conditions. Cable management systems are used vertically and horizontally on telecommunications racks to distribute cable neatly, as shown in Figure 1.

1.7 MC, IC, and HC

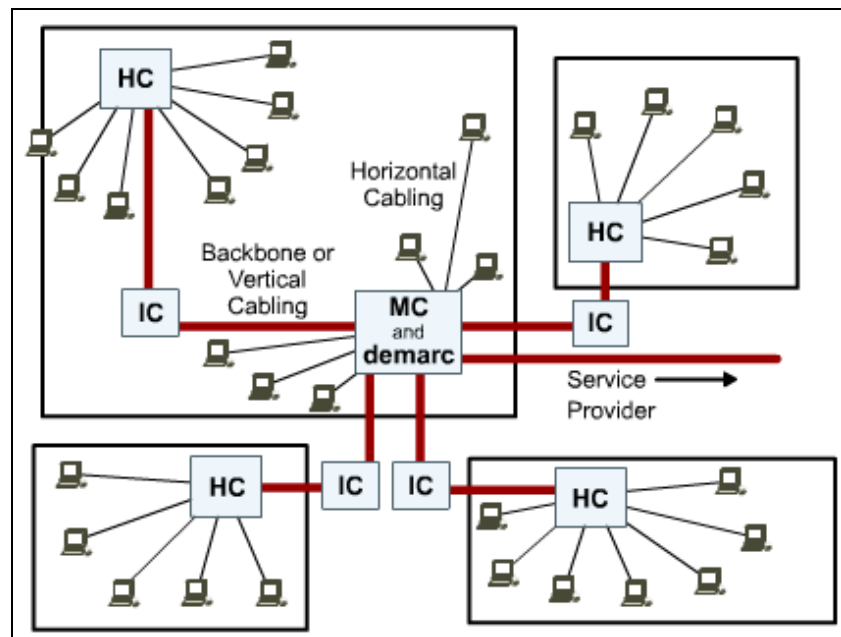

Figure 1 MC, HC, and IC Planning

Most networks have multiple TRs for various reasons. If a network is spread over many floors or buildings, a TR is needed for each floor of each building. Media can only travel a certain distance before the signal starts to degrade or attenuate. Therefore, TRs are located at defined distances throughout the LAN to provide interconnects and cross-connects to hubs and switches to assure desired network performance. These TRs house equipment such as repeaters, hubs, bridges, or switches that are needed to regenerate the signals.

The primary TR is referred to as the main cross-connect (MC). The MC is the center of the network. This is where all the wiring originates and where most of the equipment is located. The intermediate cross-connect (IC) is connected to the MC and may hold the equipment for a building on a campus. The horizontal cross-connect (HC) provides the cross-connect between the backbone and horizontal cables on a single floor of a building.

1.7.1 Main cross-connect (MC)

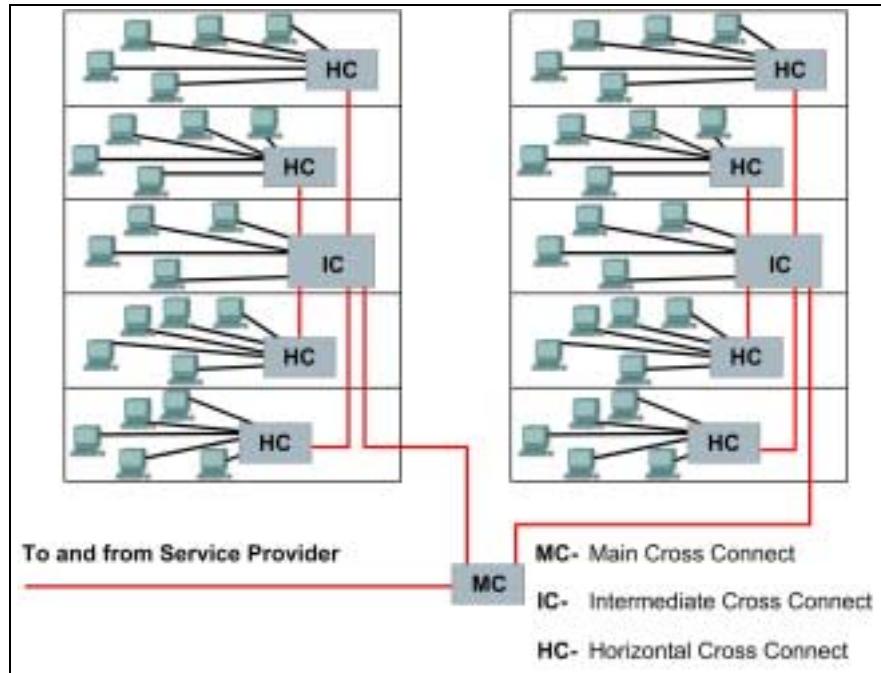

Figure 1 MC, HC, and IC

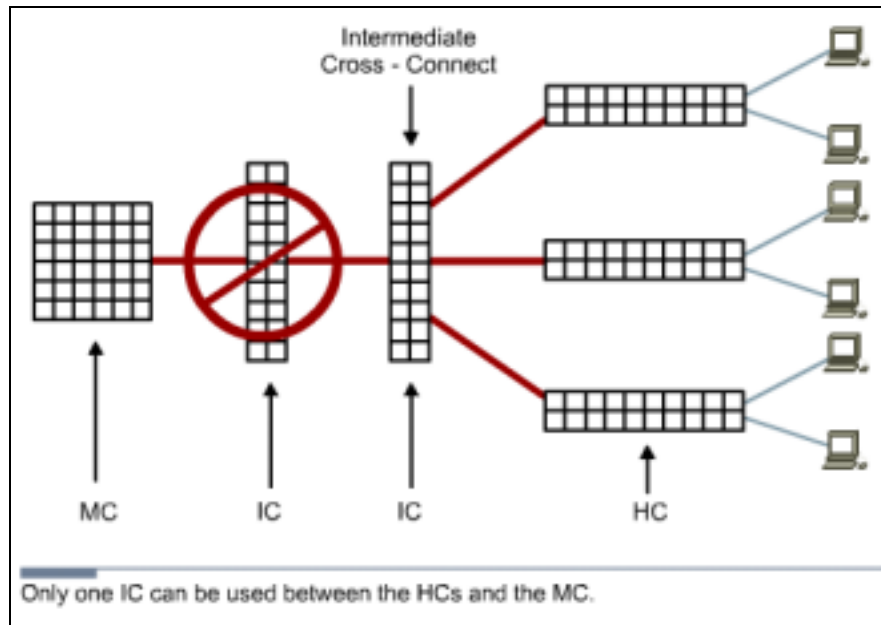

Figure 2 Connecting the MC to the IC and HCs

The MC is the main concentration point of a building or campus. It is the room that controls the rest of the TRs in a location. In some networks, it is where the cable plant connects to the outside world, or the demarc.

All ICs and HCs are connected to the MC in a star topology. Backbone, or vertical, cabling is used to connect ICs and HCs on different floors. If the entire network is confined to a single multi-story building, the MC is usually located on one of the middle floors, even if the demarc is located in an entrance facility on the first floor or in the basement.

The backbone cabling runs from the MC to each of the ICs. The red lines in Figure 1 represent the backbone cabling. The ICs are located in each of the campus buildings, and the HCs serve work areas. The black lines represent horizontal cabling from the HCs to the work areas.

For campus networks in multiple buildings, the MC is usually located in one building. Each building typically has its own version of the MC called the intermediate cross-connect (IC). The IC connects multiple HCs within the building. It also enables the extension of backbone cabling from the MC to each HC because this interconnection point does not degrade the communications signals.

As shown in Figure 2, there may only be one MC for the entire structured cabling installation. The MC feeds the ICs. Each IC feeds multiple HCs. There can only be one IC between the MC and any HC.

1.7.2 Horizontal cross-connect (HC)

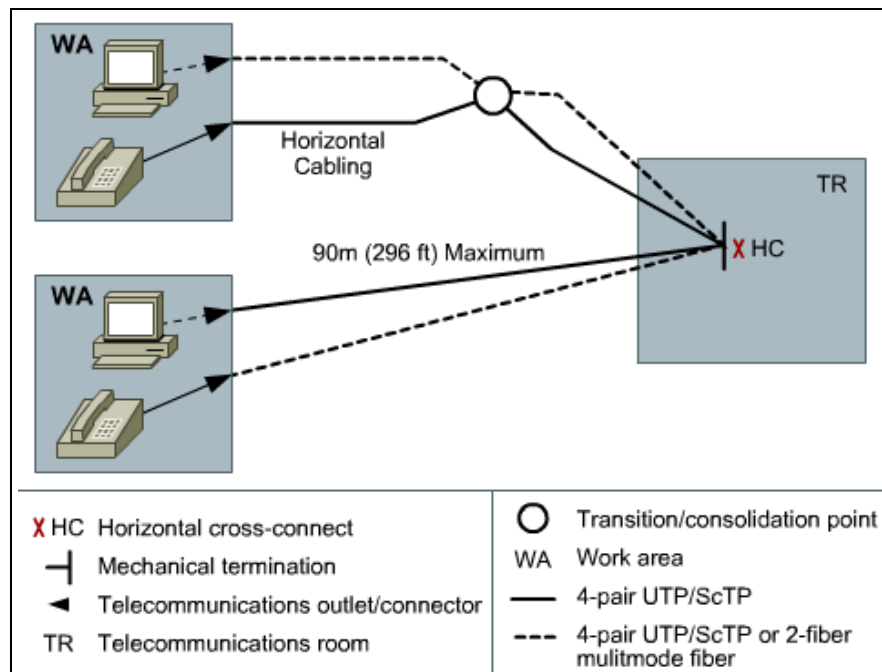

Figure 1 Horizontal Cabling and Symbols

The horizontal cross-connect (HC) is the TR closest to the work areas. The HC is typically a patch panel or punch down block. The

HC may also contain networking devices such as repeaters, hubs, or switches. It can be rack mounted in a room or in a cabinet. Since a typical horizontal cable system includes multiple cable runs to each workstation, it can represent the largest concentration of cable in the building infrastructure. A building with 1,000 workstations may contain a horizontal cable system with 2,000 to 3,000 cable runs.

Horizontal cabling includes the copper or optical fiber networking media that is used from the wiring closet to a workstation, as shown in Figure 1. Horizontal cabling also includes the networking media that runs along a horizontal pathway that leads to the telecommunications outlet, and the patch cords, or jumpers in the HC.

Any cabling between the MC and another TR is backbone cabling. The difference between horizontal and backbone cabling is defined in the standards.

[Lab 2: Terminating a Category 5e Cable on a Category 5e Patch Panel](#)

1.7.3 Backbone cabling

Any cabling installed between the MC and another TR is known as backbone cabling. The difference between horizontal and backbone cabling is clearly defined in the standards. Backbone cabling is also referred to as vertical cabling. It consists of backbone cables, intermediate and main cross-connects, mechanical terminations, and patch cords or jumpers used for backbone-to-backbone cross-connection. Backbone cabling includes the following:

- TRs on the same floor, MC to IC, and IC to HC
- Vertical connections, or risers, between TRs on different floors, such as MC to IC cabling
- Cables between TRs and demarcation points
- Cables between buildings, or inter-building cables, in a multi-building campus

The maximum distance for cabling runs depends on the type of cable installed. For backbone cabling, the maximum distance can also be affected by how the cabling will be used. For example, if single-mode fiber-optic cable will be used to connect the HC to the MC, then the maximum distance for the backbone cabling run is 3000 m (9842.5 feet).

Sometimes the maximum distance of 3000 m (9842.5 feet) must be split between two sections. For example, if the backbone cabling will connect the HC to an IC and the IC to the MC. When this occurs, the maximum distance for the backbone cabling run between the HC and the IC is 300 m (984 feet). The maximum distance for the backbone cabling run between the IC and the MC is 2700 m (8858 feet).

1.7.4 Fiber-optic backbone

The use of fiber optics is an effective way to move backbone traffic for three reasons:

- Optical fibers are impervious to electrical noise and radio frequency interference.
- Fiber does not conduct currents that can cause ground loops.
- Fiber-optic systems have high bandwidth and can work at high speeds.

A fiber-optic backbone can also be upgraded to provide even greater performance when the terminal equipment is developed and becomes available. This can make fiber optics very cost effective.

An additional advantage is that fiber can travel much farther than copper when used as a backbone media. Multimode optical fiber can cover lengths of up to 2000 meters (6561.7 feet). Single-mode fiber-optic cables can cover up to 3000 meters (9842.5 feet). Optical fiber, especially single mode fiber, can carry signals much farther. Distances of 96.6 to 112.7 km (60 to 70 miles) are possible, depending on terminal equipment. However, these longer distances are beyond the scope of the LAN standards.

1.7.5 MUTOAs and Consolidation Points

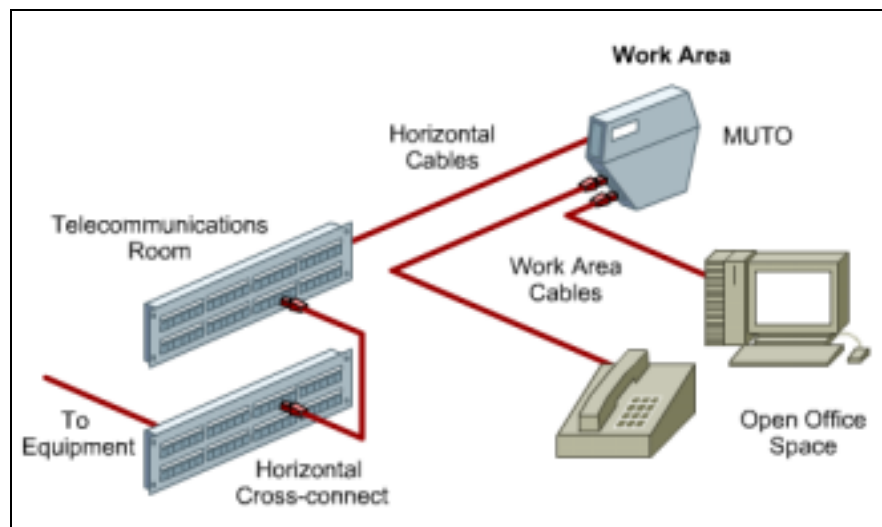

Figure 1 Typical MUTOA Installation

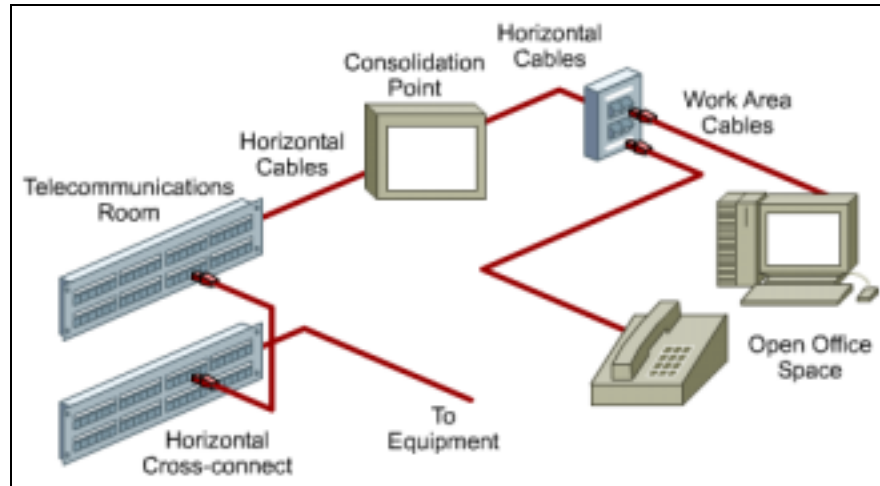

Figure 2 Typical Consolidation Point Installation

Additional specifications for horizontal cabling in work areas with moveable furniture and partitions have been included in TIA/EIA-568-B.1. Horizontal cabling methodologies using multiuser telecommunications outlet assemblies (MUTOAs) and consolidation points (CPs) are specified for open office environments. These methodologies provide increased flexibility and economy for installations that require frequent reconfiguration.

Rather than replacing the entire horizontal cabling system feeding these areas, a CP or MUTOA can be located close to the open office area and eliminate the need to replace the cabling all the way back to the TR whenever the furniture is rearranged. The cabling only needs to be replaced between the new work area outlets and the CP or MUTOA. The longer distance of cabling back to the TR remains permanent.

A MUTOA is a device that allows users to move, add devices, and make changes in modular furniture settings without re-running the cable. Patch cords can be routed directly from a MUTOA to work area equipment, as shown in Figure 1. A MUTOA location must be accessible and permanent. A MUTOA cannot be mounted in ceiling spaces or under access flooring. It cannot be mounted in furniture unless the furniture is permanently secured to the building structure.

The TIA/EIA-568-B.1 standard includes the following guidelines for MUTOAs:

- At least one MUTOA is needed for each furniture cluster.
- A maximum of 12 work areas can be served by each MUTOA.
- Patch cords at work areas should be labeled on both ends with unique identifiers.
- The maximum patch cord length is 22 m (72.2 feet).

Consolidation points (CPs) provide limited area connection access. Permanent flush wall-mounted, ceiling-mounted, or support column-mounted panels are generally used in modular furniture work areas. These panels must be unobstructed and fully accessible without moving fixtures, equipment, or heavy furniture. Workstations and other work area equipment do not plug into the CP like they do with the MUTOA, as shown in Figure 2. Workstations plug into an outlet, which is then connected to the CP.

The TIA/EIA-569 standard includes the following guidelines for CPs:

- At least one CP is needed for each furniture cluster
- Each CP can serve a maximum of 12 work areas
- The maximum patch cord length is 5 m (16.4 feet)

For both consolidation points and MUTOAs, TIA/EIA-568-B.1 recommends a separation of at least 15 m (49 feet) for equipment between the TR and the CP or MUTOAs. This is to avoid problems with crosstalk and return loss.

2 Structured Cabling Standards and Codes

Standards are sets of rules or procedures that are either widely used, or officially specified to provide a model of excellence. A single vendor specifies some standards. Industry standards support multi-vendor interoperability in the following ways:

- Standardized media and layout descriptions for both backbone and horizontal cabling
- Standard connection interfaces for the physical connection of equipment
- Consistent and uniform design that follows a system plan and basic design principles

Numerous organizations regulate and specify different types of cables. Local, state, county, and national government agencies also issue codes, specifications, and requirements.

A network that is built to standards should work well, or interoperate, with other standard network devices. The long term performance and investment value of many network cabling systems has been diminished by installers who do not comply with mandatory and voluntary standards.

These standards are constantly reviewed and periodically updated to reflect new technologies and the increasing requirements of voice and data networks. As new technologies are added to the standards, others are phased out. A network may include technologies that are no longer a part of the current standard or will soon be eliminated. These technologies do not usually require an immediate changeover. They are eventually replaced by newer and faster technologies.

Many international organizations attempt to develop universal standards. Organizations such as the IEEE, ISO, and IEC are examples of international standards bodies. These organizations include members from many nations, which all have their own process for creating standards.

In many countries, the national codes become the model for state and provincial agencies as well as municipalities and other governmental units to incorporate into their laws and ordinances. The enforcement then moves to a local authority. Always check with local authorities to determine what codes are enforced. Most local codes take precedence over national codes, which take precedence over international codes.

2.1 Telecommunications Industry Association (TIA) and Electronic Industries Alliance (EIA)

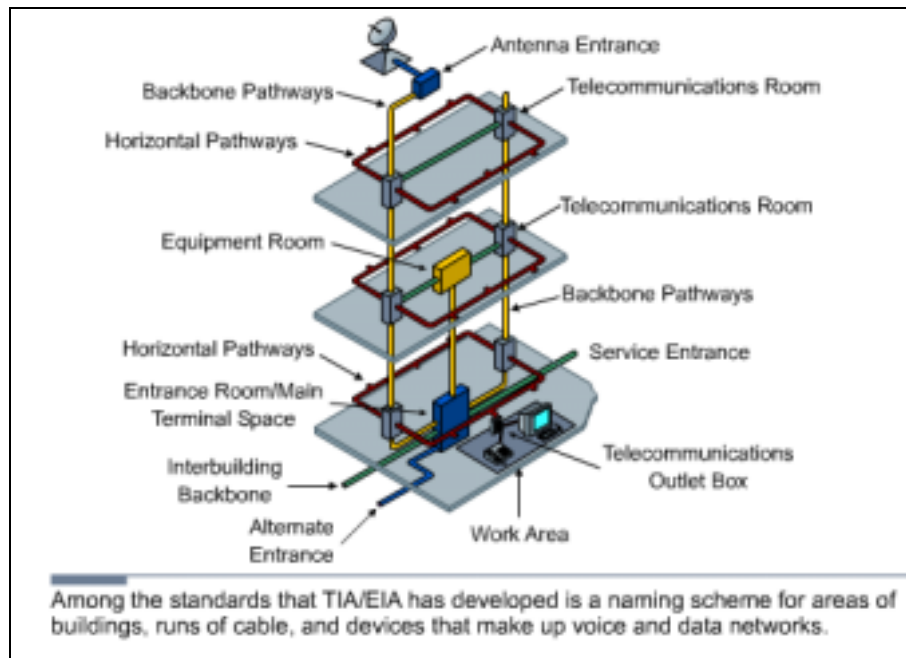

Figure 1 TIA/EIA Standards for buildings

TIA/EIA-568-B.1	Commercial Building Telecommunications Cabling Standard – General Requirements
TIA/EIA-568-B.2	Balanced Twisted Pair Cabling Components
TIA/EIA-568-B.3	Optical fiber Cabling Components
TIA/EIA-568-B	Cabling Standards
TIA/EIA-569-A	Commercial Building Standard for Telecommunications Pathways and Spaces
TIA/EIA-570-A	Residential and Light Commercial Telecommunications Wiring Standard
TIA/EIA-606	Administration Standard for the Telecommunications Infrastructure of Commercial Buildings
TIA/EIA-607	Commercial Building Grounding and Bonding Requirements for Telecommunications

Figure 2 TIA/EIA Structured Cabling Standards

The Telecommunications Industry Association (TIA) and Electronic Industries Alliance (EIA) are trade associations that develop and

publish a series of standards covering structured voice and data wiring for LANs. These standards are shown in Figure 1.

Both TIA and EIA are accredited by the American National Standards Institute (ANSI) to develop voluntary telecommunication industry standards. Many standards are labeled ANSI/TIA/EIA. The various committees and subcommittees of TIA/EIA develop standards for fiber optics, user premise equipment, network equipment, wireless communications, and satellite communications.

TIA/EIA standards

While there are many standards and supplements, the following are used most frequently by cable installers and are listed in Figure 2:

- **TIA/EIA-568-A** – This former Commercial Building Standard for Telecommunications Wiring specified minimum requirements for telecommunications cabling, recommended topology and distance limits, media and connecting hardware performance specifications, and connector and pin assignments.
- **TIA/EIA-568-B** – The current Cabling Standard specifies the component and transmission requirements for telecommunications media. The TIA/EIA-568-B standard is divided into three separate sections: 568-B.1, 568-B.2, and 568-B.3.
 - TIA/EIA-568-B.1 specifies a generic telecommunications cabling system for commercial buildings that will support a multiproduct, multivendor environment.
 - TIA/EIA-568-B.1.1 is an addendum that applies to 4-pair UTP and 4-pair screened twisted-pair (ScTP) patch cable bend radius.
 - TIA/EIA-568-B.2 specifies cabling components, transmission, system models, and the measurement procedures needed for verification of twisted pair cabling.
 - TIA/EIA-568-B.2.1 is an addendum that specifies the requirements for Category 6 cabling.
 - TIA/EIA-568-B.3 specifies the component and transmission requirements for an optical fiber cabling system.
- **TIA/EIA-569-A** – The Commercial Building Standard for Telecommunications Pathways and Spaces specifies design and construction practices within and between buildings that support telecommunications media and equipment.
- **TIA/EIA-606-A** – The Administration Standard for the Telecommunications Infrastructure of Commercial Buildings

includes standards for labeling cables. This standard specifies that each hardware termination unit should have a unique identifier. It also outlines the requirements for record keeping and maintaining documentation for administering the network.

- **TIA/EIA-607-A** – The standard for Commercial Building Grounding and Bonding Requirements for Telecommunications supports a multivendor, multiproduct environment, as well as the grounding practices for various systems that may be installed on customer premises. The standard specifies the exact interface points between the building grounding systems and the telecommunications equipment grounding configuration. The standard also specifies the building grounding and bonding configurations needed to support this equipment.

Web Link:

<http://www.tiaonline.org/>

<http://www.eia.org/>

2.2 European Committee for Electrotechnical Standardization (CENELEC)

The European Committee for Electrotechnical Standardization (CENELEC) was established as a non-profit organization under Belgian Law in 1973. CENELEC develops electrotechnical standards for most of Europe. CENELEC works with 35,000 technical experts from 22 European countries to publish standards for the European market. It is officially recognized as the European standards organization in Directive 83/189/EEC of the European Commission. Many CENELEC cabling standards are the same as ISO cabling standards, with some minor changes.

CENELEC and the International Electrotechnical Commission (IEC) operate at two different levels. However, their actions have a strong mutual impact. They are the most important standardization bodies in the electrotechnical field in Europe. Cooperation between CENELEC and the IEC is described in the Dresden Agreement. This agreement was approved and signed by both partners in the German city of Dresden in 1996. This agreement was intended to accomplish the following:

- Expedite the publication and common adoption of international standards
- Accelerate the standards preparation process in response to market demands
- Ensure rational use of available resources

Therefore, full technical consideration of the standards should preferably take place at an international level.

Web Link:

<http://www.cenelec.org/>

<http://www.iec.ch/>

2.3 International Organization for Standardization (ISO)

International Organization for Standardization (ISO) consists of national standards organizations from over 140 countries, including ANSI. ISO is a nongovernmental organization that promotes the development of standardization and related activities. The work of the ISO results in international agreements, which are published as international standards.

ISO has defined several important computer standards. The most significant standard may be the Open Systems Interconnection (OSI) model, a standardized architecture for network design.

Web Link:

<http://www.iso.org/iso/en/ISOOnline.frontpage>

2.4 U.S. Codes

Some networking projects require a permit to ensure that the work is done properly. Contact local zoning departments for information on permit requirements.

To obtain copies of local or state building codes, contact the building official for the jurisdiction. All the basic building codes throughout the United States can be purchased from the International Conference of Building Officials (ICBO). Basic building codes include CABO, ICBO, BOCA, SBCCI, and ICC.

Note: The Americans with Disabilities Act (ADA) has led to several important changes in construction, alteration, and renovation guidelines in regards to networking and telecommunications. These requirements depend on the use of the facility and fines can be assessed for failure to comply.

Many codes that require local inspection and enforcement are incorporated into state or provincial governments and then transferred to city and county enforcement units. This includes building, fire, and electrical codes. Like occupational safety, these were originally local issues, but disparity of standards and a lack of enforcement have led to national standards.

The enforcement of some codes will vary by city, county, or state. Projects within a city are generally handled by city agencies, while those outside the city are covered by county agencies. Fire codes may be enforced by county building permit departments in some communities but by local fire departments in others. Violating these codes can result in expensive penalties and delayed project costs.

Local entities inspect and enforce most codes, but the organizations that make the standards will usually write them. The National Electrical Code (NEC) is written to sound like a legal ordinance. This allows local governments to adopt the code by vote. This may not happen regularly, so it is important to know which version of the NEC is used in the area where the cabling is installed.

Note that most countries have similar systems of codes. Knowledge of these local codes is important for planning a project that crosses national boundaries.

Web Link:

<http://www.icbo.org/>

2.5 Evolution of Standards

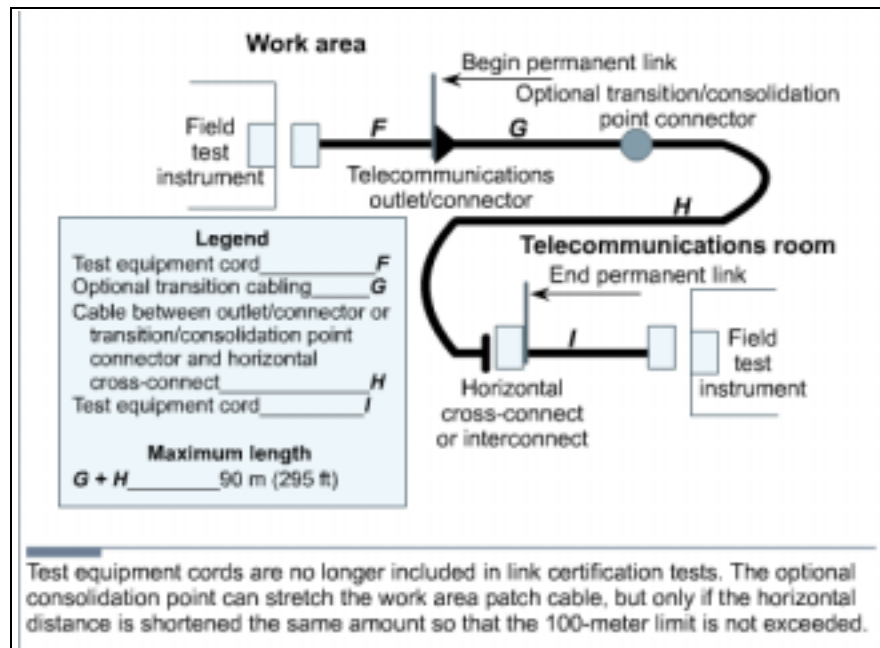

Figure 1 Changes to Horizontal Cabling Standards

When network bandwidth increased from 10 Mbps to over 1000 Mbps, it created new demands for cabling. Many types of older cable are inadequate for use in faster, modern networks. Therefore, cabling will usually change over time. The following TIA/EIA-568-B.2 standards reflect this.

For twisted-pair cables, only 100-ohm Category 3, 5e, and 6 cables are recognized. Category 5 cable is no longer recommended for new installations, and has been moved from the body of the standard to the appendix. Category 5e or greater is now the recommended cable for 100-ohm twisted pair.

The Category 6 standard specifies performance parameters that will ensure that products meeting the standard will be component compliant, backward compatible, and interoperable between vendors.

When terminating Category 5e and higher cables, the pairs should not be untwisted more than 13 mm (0.5 inch) from the point of termination. The minimum bend radius for UTP horizontal cabling remains four times the cable diameter. The minimum bend radius for UTP patch cable is now equal to the cable diameter. UTP patch cable contains stranded wires. Therefore, it is more flexible than the solid core copper cables used in horizontal cabling.

The acceptable length of patch cords in the telecommunications room has changed from a maximum length of 6 m (19.7 feet) to 5 m (16.4 feet). The maximum acceptable length of a jumper cable in the work area has changed from 3 m (9.8 feet) to 5 m (16.4 feet). The maximum horizontal segment distance is still 90 m (295 feet). If a MUTOA is used, the work area jumper length can be increased if the horizontal length is decreased for a maximum total link segment length of 100 m (328 feet). These standards are shown in Figure 1. The use of a MUTOA or Consolidation Point also mandates a separation of at least 15 meters (49 ft) between the TR and the MUTOA or Consolidation Point in order to limit problems with crosstalk and return loss.

In the past, all patch cords and cross-connect jumpers were required to be made from stranded cable to provide flexibility to survive repeated connection and reconnection. This standard now says that stranded conductors should be used. Because the phrasing of the standard uses the word *should* instead of *shall*, this allows for solid conductor cord designs.

Patch cords are critical elements in a network system. The onsite manufacturing of patch cords and jumpers is still permitted. However, network designers are strongly encouraged to purchase cables that are premade and tested.

Category 6 and the emerging Category 7 are the newest copper cables available. As Category 6 cable is used more frequently, it is important for cable installers to understand its benefits.

The main difference between Category 5e and Category 6 is the way that spacing between the pairs inside the cables is maintained. Some Category 6 cables use a physical divider down the center of the cable. Others have a unique sheath that locks the pairs into position. Another type of Category 6 cable, which is often referred to as ScTP, uses a foil screen that over wraps the pairs in the cable.

To achieve even greater performance than Category 6 and the proposed Category 7, cables use a fully-shielded construction, which limits crosstalk between all pairs. Each pair is enveloped within a foil wrap and an overall braided sheath surrounds the four foil-wrapped pairs. A drain wire may be provided in future cables to facilitate grounding.

Standards for the structured cabling will continue to evolve. The focus will be on supporting the new technologies that are converging on the data network, such as the following:

- IP telephony and Wireless utilizing a power signal in the transmission to provide power to the IP Phones or Access Points.
- Storage Area Networking (SAN) utilizing 10Gb Ethernet transmission
- Metro Ethernet “last mile” solutions that require optimizing bandwidth and distance requirements

The standard for Power over Ethernet (PoE) is under development and will be available in the near future. PoE embeds a power signal on cables used for Ethernet transmissions. This power signal is used to free IP phones and wireless access points from the need for connection to AC power outlets, simplifying deployment and reducing costs.

3 Safety

3.1 Safety Codes and Standards for the United States

Most nations have rules designed to protect workers against hazardous conditions. In the United States, the organization in charge of worker safety and health is the Occupational Safety and Health Administration (OSHA). Since the agency was created in 1971, workplace fatalities have been cut in half and occupational injury and illness rates have declined 40 percent. At the same time, U.S. employment has nearly doubled from 56 million workers at 3.5 million worksites to 105 million workers at nearly 6.9 million sites.

OSHA is responsible for enforcing U.S. labor laws to protect workers. OSHA is not a building code or building permit related agency. However, OSHA inspectors can impose heavy fines or shut down a jobsite if they find serious safety violations. Anyone who works on, or is responsible for, a construction site or business facility must be familiar with OSHA regulations. The organization offers safety information, statistics, and publications on its website.

3.1.1 MSDS

A material safety data sheet (MSDS) is a document that contains information about the use, storage, and handling of a hazardous material. An MSDS provides detailed information about the potential health effects of exposure and how to work safely with the material. It includes the following information:

- What the hazards of the material are
- How to use the material safely
- What to expect if the recommendations are not followed
- What to do if accidents occur
- How to recognize symptoms of overexposure
- What to do if such incidents occur

Web Link:

<http://www.osha.gov>

3.1.2 Underwriters Laboratories (UL)

Underwriters Laboratories (UL) is an independent, nonprofit product safety testing and certification organization. UL has tested products for public safety for over a century. The UL focuses on safety standards, but has expanded its certification program to evaluate twisted-pair LAN cables for performance. This evaluation is based on

IBM and TIA/EIA performance specifications, as well as NEC safety specifications. The UL also established a program to mark shielded and unshielded twisted-pair LAN cables. This should simplify the process of ensuring that the materials used in an installation meet the specifications.

UL initially tests and evaluates samples of cable. After granting a UL listing, the organization conducts follow-up tests and inspections. This testing process makes the UL mark a valuable symbol to buyers.

The UL LAN Certification Program addresses safety and performance. Companies with cables that earn the UL markings display them on the outer jacket. For example, Level I, LVL I, or LEV I.

Web Link:

<http://www.ul.com>

3.1.3 National Electrical Code (NEC)

The purpose of the National Electrical Code (NEC) is to safeguard people and property from hazards that arise from the use of electricity. The National Fire Protection Association (NFPA) sponsors this code with support from ANSI. The code is revised every three years.

Several organizations, including UL, have established standards for flame and smoke that apply to network cables in buildings. However, the NEC standards are more widely supported by local licensing and inspection officials.

3.1.4 The NEC Type Codes

Type of Cable	Description
OFC (fiber-optic)	Contains metal conductors, inserted for strength
OFN (fiber-optic)	Contains no metal
CMP (communication plenum)	Passed tests showing a limited spread of flame and low production of smoke. Plenum cable is typically coated with a special jacket material such as Teflon. The letter P in this code defines a plenum as a channel or ductwork fabricated for handling air.
CMR (communication riser)	The letter R shows that the cable has passed similar but slightly different tests for the spread of flame and production of smoke. For example, riser cable is tested for its burning properties in a vertical position. According to the code, you must use cable rated for riser service whenever a cable penetrates a floor and a ceiling. Riser cables typically have a polyvinyl chloride (PVC) outer jacket.

Figure 1 NEC Cable Type Codes

NEC type codes are listed in catalogs of cables and supplies. These codes classify products for specific uses, as shown in Figure 1.

Interior network cables are generally listed in the CM category for communications or MP for multipurpose. Some companies choose to run their cables through the test process as remote control or power-limited circuit cables class 2 (CL2) or class 3 (CL3) general tests instead of through the CM or CP tests. However, the flame and smoke criteria are generally the same for all tests. The differences between these markings concern the amount of electrical power that could run through the cable in the worst case. The MP cable is subjected to tests that assume the most power-handling capability. CM, CL3, and CL2 go through tests with decreasing levels of power handling.

Web Link:

<http://www.nfpa.org/Home/index.asp>

3.2 Safety Around Electricity

In addition to learning about safety organizations, cable installers should also learn about basic safety principles. These principles will be used every day on the job and are necessary for the curriculum labs. Since there are many hazards involved in cable installation, the installer should be prepared for all situations to prevent accidents or injuries.

3.2.1 High-voltage

Cable installers work with wiring designed for low-voltage systems. Most people would not notice the voltage applied to a data cable. However, the voltage of network devices that data cables plug into can range from 100 to 240 volts in North America. If a circuit failure made the voltage accessible, it could cause a dangerous or fatal shock to the installer.

Low-voltage installers must also consider the hazards of high-voltage wiring. Dangerous shocks may occur if insulation is inadvertently removed from existing high-voltage wiring. After coming in contact with high-voltage, installers may be unable to control their muscles or pull away.

3.2.2 Lightning and high-voltage danger

High-voltage is not limited to power lines. Lightning is another source of high-voltage. Lightning can be fatal or damage network equipment. Therefore, it is important to prevent lightning from entering the network cabling.

The following precautions should be taken to avoid personal injury and network damage from lightning and electrical shorts:

- All outside wiring must be equipped with properly grounded and registered signal circuit protectors at the point where they enter the building, or the entrance point. These protectors must be installed in compliance with local telephone company requirements and applicable codes. Telephone wire pairs should not be used without authorization. If authorization is obtained, do not remove or modify telephone circuit protectors or grounding wires.
- Never run wiring between structures without proper protection. In fact, protection from lightning effects is probably one of the biggest advantages of using fiber optics between buildings.
- Avoid installing wires in or near damp locations.
- Never install or connect copper wiring during electrical storms. Improperly protected copper wiring can carry a fatal lightning surge for many miles.

3.2.3 High-voltage safety test

Voltage is invisible. However, the effects of voltage are seen when equipment malfunctions or someone gets shocked.

When working with anything that plugs into a wall for power, check for voltage on surfaces and devices before coming in contact with them. Use a known reliable voltage measurement device such as a multimeter or voltage detector. Take measurements immediately

before work begins each day. Measure again after a break on any job. Recheck the measurements again when finished.

Lightning and static electricity cannot be predicted. Never install or connect copper wiring during electrical storms. Copper wiring can carry a fatal lightning surge for many kilometers. This is important to consider for external wiring between buildings or underground wiring. All outside wiring should be equipped with properly grounded and approved signal circuit protectors. These protectors must be installed in compliance with the local codes. In most cases, the local codes will align with national codes.

3.2.4 Grounding

Grounding provides a direct path to the earth for voltage. Equipment designers isolate the circuits in equipment from the chassis. The chassis is the box where the circuits are mounted. Any voltage that leaks from the equipment to its chassis should not stay in the chassis. Grounding equipment conducts any stray voltage to the earth without harming the equipment. Without a proper path to ground, stray voltage may use a different path, such as a human body.

The grounding electrode is the metal rod that is buried in the ground near the entrance point of the building. For years, cold water pipes that entered the building from underground water mains were considered good grounds. Large structural members, such as I-beams and girders, were also acceptable. Although these may provide an adequate path to ground, most local codes now require a dedicated grounding system. Grounding conductors connect equipment to grounding electrodes.

Be aware of the grounding system in the lab and on each job site. Verify that the grounding system works. Grounding is often installed incorrectly. Some installers take shortcuts to accomplish a technically adequate ground in a nonstandard way. Changes to other parts of the network or to the building may destroy or eliminate a nonstandard ground system. This would leave the equipment and people at risk.

3.2.5 Bonding

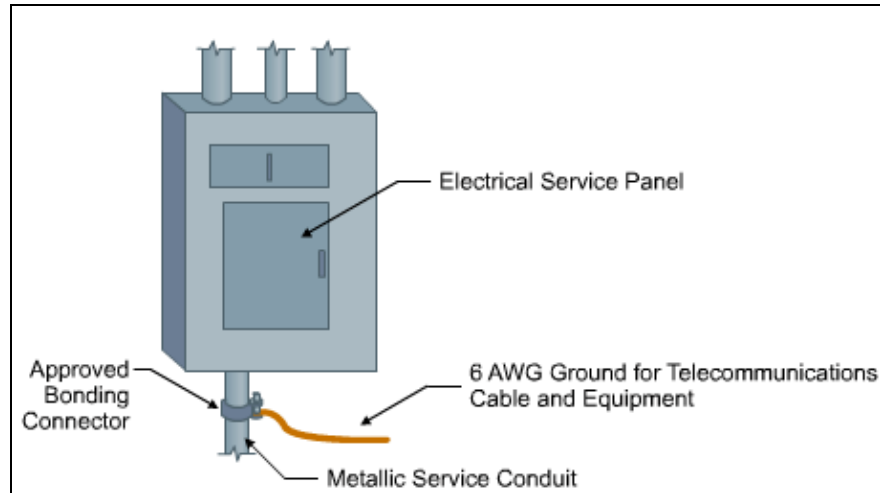

Figure 1 Bonding

Bonding allows various wiring fixtures to interconnect with the grounding system, as shown in Figure 1. Bonding is an extension of ground wiring. A device such as a switch or router may have a bonding strap between its case and a ground circuit to ensure a good connection.

Properly installed bonding and grounding will accomplish the following:

- Minimize electrical surge or spike effects
- Maintain the integrity of the electrical grounding plant
- Provide a safer and more effective path to ground

Telecommunications bonds are typically used in the following:

- Entrance facilities
- Equipment rooms
- Telecommunications rooms

3.2.6 Grounding and bonding standards

The National Electrical Code contains much information on grounding and bonding. The TIA/EIA standard on Grounding and Bonding, TIA/EIA-607-A, Commercial Building Grounding and Bonding Requirements for Telecommunications, extends grounding and bonding into the telecommunications structured cabling system. TIA/EIA-607-A specifies the exact interface points between the grounding system of a building and the telecommunication equipment grounding configuration. It supports a multivendor, multiproduct environment for the grounding practices for various systems that may be installed on customer premises. It also specifies the necessary

grounding and bonding configurations needed in the building to support this equipment.

Web Link:

<http://www.nfpa.org/>

<http://www.tiaonline.org/>

3.3 Lab and Workplace Safety Practices

Although cable installation is generally a safe profession, there are plenty of opportunities for injury. Many injuries are caused when installers come in contact with stray sources of voltage, or foreign voltages. Foreign voltages include lightning, static electricity, and voltages caused by installation faults or induction currents on network cables.

When working in walls, ceilings, or attics, first turn off power to all circuits that pass through those work areas. If it is not clear which wires pass through the section of the building being worked in, shut off all power. Never touch power cables. Even if all power to the area has been shut off, there is no way to know if circuits are still live.

Most countries have agencies that develop and administer safety standards. Some standards are designed to ensure public safety while others protect the worker. Standards that protect the worker usually cover laboratory safety, general workplace safety, compliance with environmental regulations, and hazardous waste disposal.

3.3.1 Workplace safety

The following are guidelines for keeping a workplace safe:

- Before beginning work, learn the locations of all fire extinguishers in the area. A small fire can get out of control if unable locate an extinguisher quickly.
- Always determine the local codes in advance. Some building codes may prohibit drilling or cutting holes in certain areas such as firewalls or ceilings. The site administrator or facility engineer will be able to help identify which areas are off limits.
- When installing cable between floors, use a riser-rated cable. Riser cable is covered with a flame retardant fluorinated ethylene propylene (FEP) jacket to prevent flames from reaching another floor through the cable.
- Outdoor cables typically have a polyethylene jacket. Polyethylene burns readily and gives off dangerous gases. NEC codes state that polyethylene building entrance cables cannot be exposed more than 15 m (49.2 feet) into a building. If greater distances are required, the cable must be in metallic conduits.

- The building maintenance engineer should be consulted to determine if there is asbestos, lead, or PCB in the work area. If so, follow all government regulations in dealing with hazardous materials. Do not risk personal health by working unprotected in these areas.
- If cable must be routed through spaces where air is circulated, be sure to use a fire-rated, or plenum-rated, cable. The most common plenum cables are jacketed with Teflon or Halar. Plenum grade cable does not give off poisonous gases when it burns like regular cables, which have a polyvinyl chloride (PVC) jacket.

3.3.2 Ladder safety

Ladders come in many sizes and shapes for specific tasks. They can be made of wood, aluminum, or fiberglass and designed for either light or industrial use. The two most common types are straight ladders and stepladders. Regardless of the type or construction, make sure the ladder is certified, and complies with ANSI specifications and UL standards.

Select the right ladder for the job. The ladder should be long enough to work from comfortably and sturdy enough to withstand repeated use. Fiberglass ladders are most commonly used in cable installation. Aluminum ladders weigh less, but they are also less stable and should never be used around electricity. When working near electricity, fiberglass ladders should always be used.

Inspect the ladder first. Any ladder can develop a problem that makes it unsafe. Inspect ladders for loose or damaged rungs, steps, rails, or braces. Make sure that the spreaders on stepladders can be locked in place and that the ladder has safety feet. Safety feet provide extra stability and reduce the chances of the ladder slipping while working. Never use a defective ladder.

Stepladders should be fully opened with the hinges locked. Straight ladders should be placed at a four-to-one ratio. This means the base of the ladder should be 0.25 m (10 inches) away from the wall or other vertical surface for every 1 m (3.3 feet) of height to the point of support. Secure a straight ladder as close to the point of support as possible to prevent shifting. Ladders should always be placed on a solid, level surface.

Never climb higher than the second step from the top on a stepladder, or the third from the top on a straight ladder.

Cordon off the work area with appropriate markers such as traffic cones or caution tape. Post signs so that people are aware of the ladder. Lock or block any nearby doors that may come in contact with the ladder.

3.3.3 Fiber-optic safety

Since fiber-optic cable contains glass, it is important to take appropriate precautions. The scrap material is sharp and must be disposed of properly. If broken, tiny slivers can be lodged into the skin.

These rules should be followed to avoid injury when working with fiber optics:

- Always wear safety glasses with side shields.
- Place a mat or piece of adhesive on the table so that all glass shards that fall are easily identified.
- Do not touch eyes or contact lenses while working with fiber-optic systems until hands have been thoroughly cleaned.
- Put all cut fiber pieces in a safe place and dispose of them properly.
- Use a piece of adhesive or masking tape to remove any material that gets on clothing. Use tape to remove shards from fingers and hands.
- Do not bring food or beverages in the work area.
- Do not look directly into the end of fiber cables. Some laser driven devices could cause irreversible damage to the eye.

3.3.4 Fire extinguisher use

Never attempt to fight a fire without knowing how to use a fire extinguisher. Read the instructions and check the valve. In the United States, fire extinguishers used in commercial buildings must be checked at regular intervals. If they are not in good working order, they must be replaced.

Note If someone catches on fire, remember the tip, Stop, Drop, and Roll. Do not run. Fire spreads quickly if a burning person starts running. If a burning person panics and runs down the hall, tackle that person. Drop to the floor and roll on the floor to extinguish the flames.

Fire extinguishers have labels that identify the types of fires that they are designed to fight. In the United States, these are called ratings. Four different types of fires have been classified in the United States:

- Class A fires are ordinary materials like burning paper, lumber, cardboard, and plastics.
- Class B fires involve flammable or combustible liquids such as gasoline, kerosene, and common organic solvents used in the laboratory.
- Class C fires involve energized electrical equipment such as appliances, switches, panel boxes, power tools, hot plates,

and most other electronic devices. Water is a dangerous extinguishing medium for class C fires because of the risk of electrical shock.

- Class D fires involve combustible metals such as magnesium, titanium, potassium, and sodium. These materials burn at high temperatures and will react violently with water, air, and other chemicals.

3.4 Personal Safety Equipment

One aspect of work safety is wearing the proper work attire. Protective clothing or gear can prevent an injury or make it less severe.

When working with power tools, it is important to protect eyes from flying debris and ears from deafening noises. If goggles and earplugs are not used, eyesight or hearing could be damaged permanently

3.4.1 Work clothes

Long trousers and sleeves help protect the arms and legs from cuts, scratches, and other hazards. Avoid wearing excessively loose or baggy clothing because it may catch on a protruding object or get caught in power tools.

Wear sturdy, fully enclosed, and appropriate shoes for the job. They should protect the soles of the feet from sharp objects on the floor. Thick-soled shoes are best when working around nails, scrap metal, and other materials. Steel-toed shoes can protect toes from falling objects. Soles should also have traction to prevent slipping.

3.4.2 Eye protection

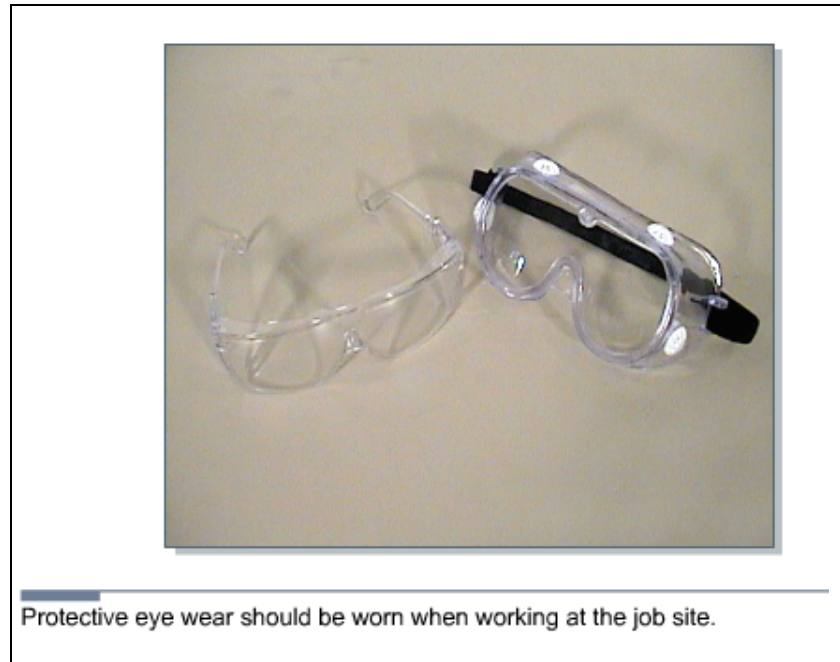

Figure 1 Eye Protection

Eyes are much easier to protect than to repair. Safety glasses should be worn when cutting, drilling, sawing, or working in a crawl space. Two types of safety glasses are shown in Figure 1. When materials are cut, prepped, and discarded during cable termination processes, small particles may become airborne. When working with fiber optics, the glass fibers, adhesives, and solvents can come in contact with the eyes. Glasses also protect the eyes from contaminated hands. Small particles or chemicals on fingers may be rubbed into the eyes. Safety glasses should also be worn when working in a crawl space or above a dropped ceiling to protect eyes from falling objects. Many job sites require safety glasses at all times.

Eye protection should be worn in all labs. Before starting any lab exercise, review the safety instructions and safety equipment needed.

3.4.3 Hard hat use

Hard hats may be required at job sites, especially those involving construction. Many employers will supply hard hats or require installers to buy their own. Hard hats may display company colors or logos to identify the wearer as belonging to a certain organization. If purchasing a hard hat for personal use, do not decorate it without permission from the employer. OSHA does not allow stickers on hard hats since they could hide cracks.

Periodically check the hard hat for cracks. A cracked hat may fail to protect a head. For hardhats to provide effective protection, they must be adjusted properly. Adjust the internal straps and ensure that the hat

fits snugly and comfortably. Hard hats are required when working on top of a ladder and are often required when working in new construction environments.

4 Tools of the Trade

4.1 Stripping and Cutting Tools



Figure 1 Panduit UTP Cable Stripping Tool



Figure 2 Electrician Scissors and Cable Knife

Stripping tools are used to cut cable jackets and wire insulation. The Panduit UTP cable-stripping tool, which is shown in Figure 1, is used to remove the outer jacket from four-pair cables. It can also be used for most coaxial cable. The tool features an adjustable cutting blade to accommodate cables with different jacket thickness. The cable is inserted into the tool. Then the tool is twisted around the cable. The blade cuts through the outer jacket only, allowing the installer to pull the jacket off of the cable to expose the twisted pairs.

The electrician scissors and cable knife set, shown in Figure 2, can also be used to remove cable jackets. The knife is used for large cables such as those that enter the building from the telco or ISP. This knife is very sharp so gloves should be worn when working with it. The gloves should be able to protect the hand from injury if the knife slips.

The scissors can be used to cut individual wires, remove the outer jacket of smaller cables, and remove the insulation on individual wires. The scissors have two different size notches on the back of the blade that will strip insulation on 22-gauge to 26-gauge wires.

4.2 Termination Tools



Figure 1 Panduit Multi-Pair Impact Tool



Figure 2 Panduit Impact Tool

Termination tools are designed to cut and terminate specific types of cable. The multi-pair termination tool, which is shown in Figure 1, is designed to terminate and cut UTP cable and seat connecting blocks. This tool features an ergonomically designed handle, which helps reduce fatigue when trimming wire or seating connecting blocks to the wiring base. It also has the following features:

- Five pairs can be terminated at a time.
- Wires on both the cable side and the cross-connect side of connecting blocks can be terminated.
- Replacement cutting blades are available.
- It can be used in the cut or non-cut position.
- The cut designation is clearly displayed for proper orientation during termination.
- The impact mechanism is reliable.
- The ergonomically designed rubber handle has a ribbed edge, which provides a no-slip grip.

The impact punch down tool, which is shown in Figure 2, has interchangeable blades. This tool can terminate wires on 66 and 110 hardware. Unlike the multi-pair termination tool, this tool terminates one wire at a time. The reversible blades have a punch and cut function on one side and a punch only function on the other.

[Lab 3: Tool Usage and Safety](#)

4.3 Diagnostic Tools

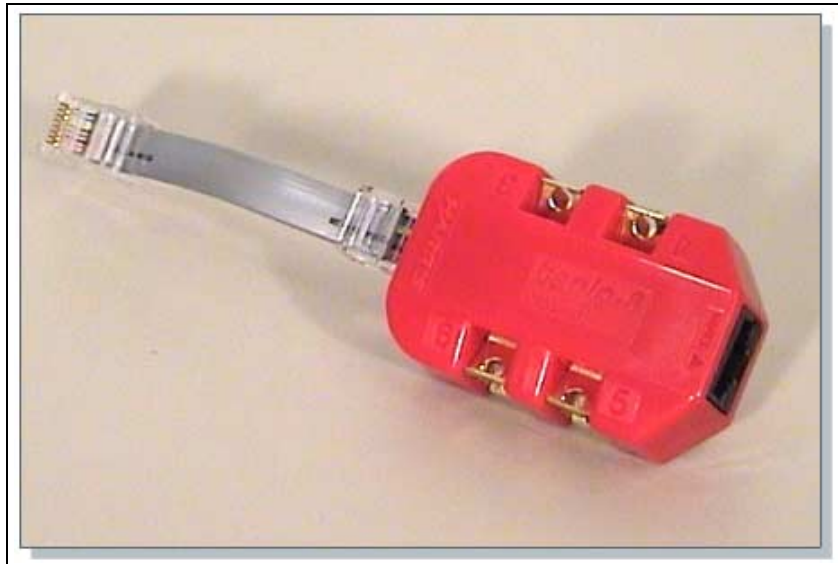

Figure 1 Modular Adapter (Banjo)

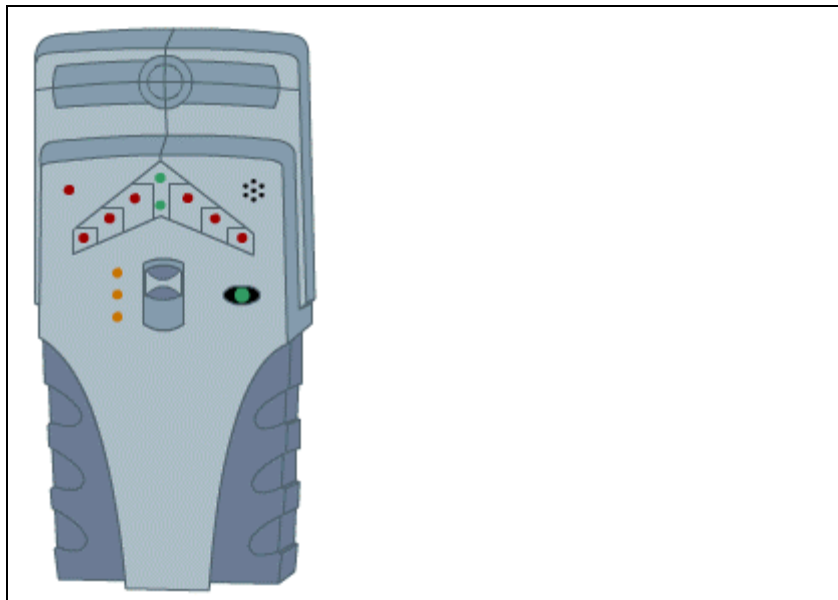

Figure 2 Stud Sensor

The modular adapter, or banjo, is used to provide access to individual wires inside a telecommunications outlet or jack. This tool is shown in Figure 1. A common line cord is plugged into the adapters and then into the jack. Technicians can use ohmmeters or other test devices without having to disassemble the jack. Banjos come in 3-pair and 4-pair configurations.

Wood and metal sensors are used to locate metal pipes, wood studs or joists, or other infrastructure behind a wall or under a floor. Sensors should be used before drilling for any cabling project. A deep

scanning metal sensor can find metal studs, conduit, copper piping, electrical lines, rebar, telephone lines, cable lines, nails, and other metal objects. This tool can usually scan through up to 15 cm (6 inches) of a nonmetallic surface like concrete, stucco, wood, or vinyl siding. It identifies both the location and depth of piping or rebar.

Another type of sensor is a stud sensor, which is shown in Figure 2. This sensor locates wooden studs and joists behind walls. This tool helps installers determine the best locations to drill or saw when installing outlets or raceways. The stud and rebar sensor also detects metal and can find rebar embedded in up to 100 cm (39.4 inches) of concrete. All the modes detect AC wires to prevent installers from drilling or nailing into a live electrical wire.

4.4 Installation Support Tools



Figure 1 Measuring Wheel

Cable installers often use measuring wheels to estimate the length of a cable run. The wheel, which is shown in Figure 1, has a counter mounted on the side. An installer rolls the wheel down the intended cable path. At the end of the path, the counter will display the distance.

Cable installers also need tools and materials for cleaning up job sites. Brooms, dustpans, and vacuums simplify the cleanup process. Cleanup is one of the final and most important steps in completing a cabling project. A shop vacuum is designed for industrial jobs.

4.4.1 Fish tape



Figure 1 Fish Tape

Fish tapes are designed to simplify the retrieval of wires inside a wall. A fish tape, which is shown in Figure 1, can be passed through walls or conduits. First the fish tape is run to its intended destination or some convenient partway point. Then the cable is secured to the end of the fish tape. Pulling the fish tape, winding it onto its reel for storage, retrieves the desired cable.

For cabling work, fiberglass fish tape is safer than steel fish tape. Most cable installers pull a string with their cables. This provides a convenient way to pull extra cables later on. The cable can be tied to the pull string and pulled through the path rather than having to use the fish tape once more.

4.4.2 Cable tree

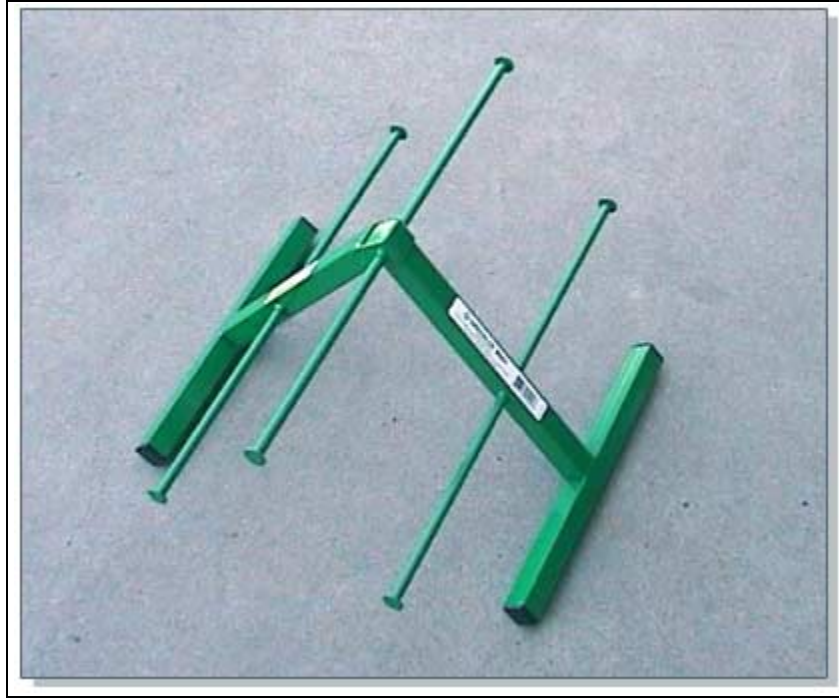

Figure 1 Cable Tree

During the rough-in phase, cable trees, jacks, and rollers are used to support cable reels. This simplifies the process of laying cables and helps prevent injuries. A cable tree, which is shown in Figure 1, supports several small reels of cable. This allows the cable installer to pull multiple runs of cable simultaneously. Since all cables terminate at the TR, a cable tree is set up in the staging area. After cable is pulled to a jack location, the other end is cut from the reel and pulled into the TR.

Cable jacks and reel rollers are designed for the large reels that hold backbone cabling. Since many large reels are too heavy to lift, cable jacks provide enough leverage to allow two people to raise them. Once raised, the jacks allow the reel to rotate freely and safely during the pulling process.

Reel rollers are also used to support large cable reels. Rollers come in sets of two. Each roller is used to support one side of the reel. Rollers mounted on bearings allow the reel to be turned easily. When pulling from a reel roller, one installer is generally stationed at the reel to assist with the turning.

4.4.3 Bullwheels

Bullwheels are normally used for the first or last turn in a path. They can also be used for an offset or turn in the center of a run.

A bullwheel is a large pulley that is used in a mechanical cable pulling process. Bullwheels are seldom used to pull a cable by hand. A bullwheel is generally made of aluminum, is at least 30 cm (12 inches) in diameter, and is supported on a bearing on its frame. Unlike a pulley, a bullwheel often has two shackles for attachment to fixed points. It can also be removed from its frame and put in a cable run from the middle of the cable.

4.4.4 Pulleys

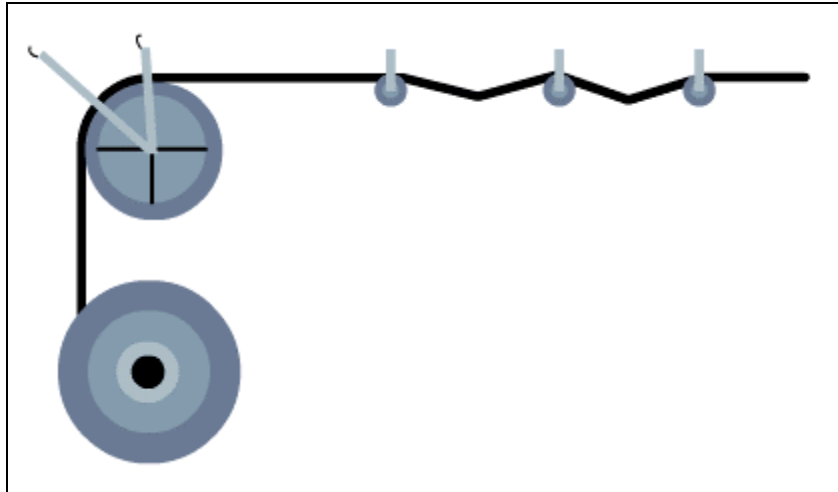

Figure 1 Cable Pull Using a Bullwheel and Pulleys

Pulleys are used on long, open cable runs to support cables and prevent them from dragging on surfaces that could damage the cable sheath. They are also used on surfaces that could be damaged by a cable being pulled across it. Pulleys are used in straight cable runs to support the weight of the cable and reduce pulling friction. Pulleys can also assist with minor offsets in the cable run. A cable run using pulleys is shown in Figure 1.

Pulleys are used when pulling by hand or when using a cable puller or winch. When turns in the run exceed 45 degrees, bullwheels are used instead.

Pulleys are used for multiple network cable runs and heavy backbone cable runs. Lightweight pulleys can be used for network cable runs, while heavy-duty pulleys should be used for backbone cables. Backbone cable pulleys have a larger frame and the pulley wheel is a larger diameter.

4.4.5 Wire mesh or Kellem grips



Figure 1 Wire Mesh or Kellem Grip

Wire mesh or Kellem grips allow pulling ropes to be tied to the end of a cable. The grip is slid over the end of the cable, and the last 15 cm (6 inches) are taped tightly with a good quality vinyl electrical tape. As tension is placed on the cable, the grip draws tighter around the sheath of the cable. These grips are generally designed for single cable use and should not be used with a bundle of network distribution cables. These grips come in various sizes to accommodate different cable sizes. A Kellem grip is shown in Figure 1.

Kellem grips are also available in a split version, if the end of the cable is not accessible. Split versions are used to pull additional slack in the middle of a cable run. Split grips are also used to support large backbone cables in riser installations, when cables are pulled between floors. To attach split Kellem grips, the grip is opened and placed around the cable. A special rod is then threaded through the wire mesh.

5 Installation Process

There are four phases that cover all aspects of a cabling project:

- **Rough-In Phase** – In the rough-in phase, all of the cables are installed in the ceilings, walls, floor ducts, and risers.
- **Trim Out Phase** – The main tasks during the trim out phase are cable management and the termination of wires.
- **Finish Phase** – The main tasks during the finish phase are cable testing, troubleshooting, and certification.
- **Customer Support Phase** – In this phase, the customer conducts a walk-through of the network and is presented with formal test results and other documentation, like as-built drawings. If satisfied, the customer will sign off on the project. The cable installation company will provide ongoing support to the customer if there are problems with the cabling.

5.1 Rough-In Phase

During the rough-in phase the cable is pulled from a work area, or staging area, to individual rooms or work areas. Each cable is labeled on both ends for identification. In the work area, extra cable should be pulled so that there is plenty to work with when terminating. If a cable will run behind a wall, it is pulled out at the termination end so that it is ready for termination in the next phase.

A new construction environment is usually less challenging than a remodeling project since there are fewer obstructions. Most new environments do not require special planning. Structures that will support cables and terminals are generally built as needed. However, coordination on the job site is essential. Other workers must be aware of data cable locations to avoid damaging the newly installed cables.

The cable installation operation begins in the staging area. This area is generally located near the TR since one end of every cable will be terminated in the TR. Proper set up of equipment will save time during the cable pulling process. Different types of cable runs will require different setups. Network distribution cabling normally requires multiple small cable reels. Backbone cabling generally requires a single large reel of cable.

[Lab 4: Identification of Cables](#)

5.1.1 Horizontal cable installation

Horizontal cable is cable that travels between the HC and the work area outlet. The cable can travel either horizontally or vertically. During the installation of horizontal cable, it is important to follow these guidelines:

- Cables should always run parallel to walls.
- Cables should never be placed diagonally across a ceiling.
- The cabling path should be the most direct path with the fewest number of turns.
- Cables should not be placed directly on top of ceiling tiles.

After the backbone cabling has been installed, the horizontal network distribution cable must be installed. Network distribution cable provides network connectivity from the backbone cabling. Network distribution cable usually travels from workstations back to the TR, where it is interconnected to the backbone cabling.

5.1.2 Horizontal cable installation in conduits



Figure 1 Conduit Blowing System

The installation of horizontal cables in conduits requires similar setups and procedures as the installation of cables in an open ceiling. Pulleys are not necessary since the cables are supported within the conduits. Although the initial staging is the same, there are some special techniques and considerations for cable pulls in conduits.

The conduit must be large enough to handle all the cables that are being pulled. Conduits should never be filled to over 40 percent of

their capacity. There are charts that list the maximum cable fill for specific conduits. The length of the run and the number of 90-degree bends in the conduit must also be considered. Conduit runs should not exceed 30 m (98 feet) without a pull box and should not have more than two 90-degree bends. Large cable pulls require long-radius conduits for the bends. The standard radius for a 10-cm (4-inch) conduit is 60 cm (24 inches). A conduit with a radius of at least 90 cm (35 inches) should be used in larger pulls.

A specialized vacuum cleaner attachment, which can help with conduit runs, is shown in Figure 1. A special foam rubber missile, sometimes referred to as a mouse, can be inserted into the conduit with a light pull string tied to the missile. When the missile is slightly lubricated with liquid detergent, a high-powered vacuum cleaner can draw the missile and the pull string through an entire conduit run. Special attachments for the vacuum can also be used to blow the missile through the conduit. For difficult runs, one vacuum can be used to blow on one end while another vacuum pulls at the other end. When the string reaches the other end of the conduit, it is used to pull the cables through the conduit.

5.1.3 Raceways



Figure 1 Raceways

A raceway is a channel that contains cables in an installation. Raceways include common electrical conduits, specialized cable trays or ladder racks, in-floor duct systems, and plastic or metal surface mounted raceways.

Surface mounted raceways, like the ones shown in Figure 1, are used when there is no hidden path for the cable. Plastic surface mounted raceway comes in various sizes to accommodate any number of

cables. These are easier to install than metallic conduits and are considered to be much more attractive.

5.1.4 Pulling cable to the jacks

In the work area, cables must be pulled to a jack or outlet location. If conduits are used to run behind the walls from the ceiling to the outlet boxes, a fish tape can be inserted into the outlet box at one end of the conduit and pushed up the conduit into the open ceiling. The cable can be attached directly to the fish tape and then pulled down from the ceiling and out through the outlet box.

Some walls, such as concrete or brick walls cannot have cable runs behind them. Therefore, surface mounted raceways are used. Before installing cables, the surface mounted raceways should be secured to the wall according to the recommendations of the manufacturer. After the cable has been pulled to the outlets, the cable installer will return to the TR to pull the cable at that end.

5.1.5 Fastening cable



Figure 1 Panduit Hook and Loop Ties

The final step in the rough-in process is to permanently fasten the cables. Many types of fasteners are available, such as nylon cable ties or hook and loop ties, as shown in Figure 1. Network cables should never be tied to electrical cables. This may appear to be the most practical approach, especially for individual cables or small bundles. However, it violates the electrical code. Cables should never be tied to water or sprinkler pipes.

High performance networks cables have a minimum bend radius that cannot exceed four times the diameter of the cable. Therefore, use fasteners that support the minimum bend radius. Fastener spacing may be defined in the job specifications. If no spacing is specified, fasteners should be placed at intervals that do not exceed 1.5 m (5 feet). If a cable tray or basket is installed in the ceiling, permanent fasteners are not necessary.

5.1.6 Horizontal cabling precautions

It is important to avoid damaging the cable or its sheath when pulling it. Too much tension or making corners so tight that they exceed the bend radius can decrease the ability of a cable to carry data. Installers stationed along the route of the pull should watch for snags and possible trouble spots before damage occurs.

Several precautions should be taken when pulling horizontal cabling:

- As the cable enters the conduit, it can become caught or get scuffed on the end of the conduit. Use a plastic conduit guard or shoe to avoid this type of sheath damage.
- Extremely hard pulls around a 90-degree turn can cause cables to flatten, even when using bullwheels and pulleys. If pulling tension is too great, shorten the length of the pull and do it in stages. Do not exceed a pull tension of 110 N (25 lbf) for unshielded twisted pair cable, or 222 N (50 lbf) for fiber.
- When pulling with a cable puller or winch, it is important to perform the pull in a single smooth action. After beginning the pull, try to continue the pull until completion. Stopping and starting can cause additional stress to the cable.

5.1.7 Mounting jacks in drywall

SAFETY RULES

When working in walls, ceilings, or attics, the first thing to do is turn off power to all circuits that might pass through those work areas. If it is not clear whether wires pass through the section of the building being worked in, a good rule to follow is to shut off all power.

WARNING: Never, ever, touch power cables. Even if all power has been cut to the area being worked in, there is no way to know if they are "live".

Before beginning work, learn the locations of all fire extinguishers in the area.

Wear appropriate clothing. Long pants and sleeves help protect arms and legs. Excessively loose or baggy clothing should not be worn as it could catch on something.

If working in a dropped ceiling area, survey the area. Do this by lifting a few of the ceiling tiles and looking around. This will help to locate electrical conduit, air ducts, mechanical equipment, and anything that might possibly cause problems later.

Protect the eyes with safety glasses when cutting or sawing. It is also a good idea to wear safety glasses when working in a crawl space or above a dropped ceiling. If something falls from above, or in the dark, the eyes will be protected.

Consult the maintenance engineer of the building to find out if there is asbestos, lead, or PCBs where the work is being done. If so, follow all government regulations in dealing with that material.

Keep the work area orderly and neat. Do not leave tools lying in places where someone might trip over them. Use caution with tools that have long extension cords. Like tools, they are easy to trip over.

To mount an RJ-45 jack in drywall, follow these steps:

1. Select a position for the jack that will be 30-45 cm (10-15 inches) above the floor. Drill a small hole in the selected location. Check for any obstructions behind the hole by bending a piece of wire, inserting it into the hole, and rotating it in a circle. If the wire hits something, there is an obstruction there and a new location farther away from the first hole must be selected. Then the procedure must be done again until an unobstructed location can be found.

CAUTION *When working in walls, ceilings, or attics, it is extremely important to remember to turn off the power to all circuits that go to, or pass through, the work area. If it is unclear whether there are wires that pass through the section of the building, a good rule to follow is to shut off all power.*

2. Determine the size of the opening needed for the box that will hold the jack. This can be done by tracing an outline of the template that was included with the box or bracket.
3. Before cutting into the wall, use a carpenter's level to make sure the opening will be straight. Use a utility knife to cut the opening. Push the knife through the drywall, inside the template outline, until there is an opening large enough to accommodate the blade of either a keyhole saw or a drywall saw.
4. Insert the saw into the hole, and cut along the edge of the penciled outline. Continue cutting carefully along the line until the piece of drywall can be pulled out. Make sure the box or bracket will fit the opening.
5. If using a box to flush-mount the jack, do not secure the box until after bringing the cable to the opening.

5.1.8 Mounting jacks in plaster

It is more difficult to cut into a plaster wall than it is to cut into drywall. To achieve the best results, follow these steps:

1. Determine the appropriate location for the jack.
2. Use a hammer and chisel to remove the plaster from the wall so that the lath behind the plaster is exposed.
3. Use a utility knife to carefully trim plaster away from the lath.
4. Place the template against the lathwork so that it overlaps three strips of lath, equally, at the top and bottom of the opening. Trace an outline around the template. Use an electric saw to cut away the full lath strip that is exposed in the center of the opening.
5. Make several small cuts on the full strip, first on one side, and then on the other. Continue to make these small cuts until the center lath has been completely cut through.

CAUTION *Be careful when doing this step. If attempting to cut all the way through one side before cutting into the other side, the saw will cause the lath to vibrate when making the second cut. This can cause the plaster around the opening to crack and separate from the lath.*

6. Finish preparing the opening by removing the required portions of the lath strips at the top and bottom. Do this by cutting vertically along the sides of the hole. Make several small cuts on first on one side and then on the other as before. Continue until the laths are notched even with the top and bottom of the hole. Now cut a curve in the bottom piece of lath from the top right corner to the bottom left corner. Bottom out the curve so that it is flat just before it gets to the corner. Remove the lath that should fall free when the cut reaches the corner. Turn the saw around and cut flush along the bottom of the hole until the opposite corner is reached. The remaining lath should fall free. Repeat the process for the top piece of lath.

5.1.9 Mounting jacks in wood

To prepare the wood for flush mounting a jack, follow these steps:

1. Select the position where the box will be placed. Remember, if the RJ-45 jack is placed on a wooden baseboard, avoid cutting the box opening into the bottom 5 cm (2 inches) of the baseboard.
2. Use the box as a template, and trace around the outside. Drill a starter hole in each corner of the outline.
3. Insert a keyhole saw, or jigsaw, into one of the holes and saw along the outline until reaching the next hole. Turn the saw and continue cutting until the piece of wood can be removed.

5.1.10 Flush mounting a jack in a wall

After preparing an opening in which to position the jack, place it in the wall. If using a box to mount the jack, hold the cable, and feed it through one of the slots into the box. Then push the box into the wall opening. Use the screws to secure the box to the wall's surface. As the screws are tightened, the box will be pulled tighter to the wall.

If mounting the jack in a flat low-voltage mounting bracket, sometimes called a "wallboard adapter" or "old work box" box, position it now. Place the bracket against the wall opening, the smooth side facing outward. Push the top and bottom flanges toward the back so that the bracket grips the wall. Then, push one side up and the other down, to securely mount the bracket.

5.1.11 Pulling cable to the jacks

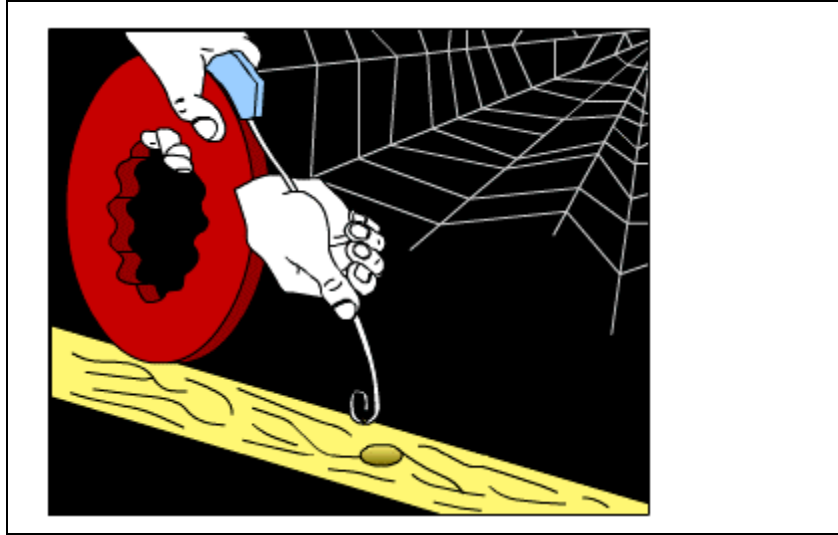

Figure 1 Pulling cable to the jacks with a fish tape

At the work area end of the cables, the cable must be pulled to the jack or outlet location. If conduits are used to run behind the walls from the ceiling to the outlet boxes, a fish tape can be inserted into the outlet box at the end of the conduit and pushed up the conduit until it comes out into the open ceiling. The cable can be attached directly to the fish tape and then pulled down from the ceiling and out through the outlet box as shown in Figure 1.

If there are no conduits in the walls, the cable can be pulled behind the wall. First, a hole is cut into the drywall at the location of the jack. Care must be taken to avoid making the hole too large. Another hole is drilled into the top plate of the wall. This hole should be 1–2 cm (0.4–0.8 inches) in diameter. A fish tape is pushed down through the top hole, and the installer must try to find it at the lower hole. Some installers use a weight and a string instead, which is dropped down from the top hole and tied off so that it cannot accidentally drop down through the hole. At the bottom hole, or outlet, the installer can use a hook or a coat hanger to try to find the string.

Once the end of the fish tape is captured at the outlet location, a pull string is tied to it. The fish tape is then pulled back up to the original location where the cables are tied to the pull string. Finally, the pull string is pulled down to the outlet location with the cables attached.

Some walls, like concrete or brick walls, will obviously not have the cables run behind them. Surface mounted raceways are used for these types of walls instead. Before cables are installed, the surface mounted raceways should be secured to the wall following the manufacturer's recommendations. After cable has been pulled through to the outlets, the cable installers return to the telecommunications room to finish pulling the cable at that end.

5.1.12 Fishing cable from below a wall

When running horizontal cabling in a building that has a basement, fish cable from there to the work areas on the first floor. Do this by following these steps:

1. Drill a 3.2 mm (1/8-inch) hole, at an angle, through the floor, next to a baseboard.
2. Push a coat hanger or stiff piece of wire into the hole to indicate the spot when in the basement.
3. Go to the basement and locate the wire.
4. Use a tape measure to mark a spot under the areas of the wall. This mark should be 57 mm (2 inches) from the hole.
5. Drill a new hole in this spot. This hole should be 19 mm (0.7 inches) in diameter. Unlike the first hole that was drilled at an angle, drill this hole straight up through the subfloor and wall plate.
6. Push the cable up through this second hole, to the wall opening where the work area outlet is to be located.
7. Be sure to allow enough excess cable so that it can reach the floor and extend another 60–90 cm (2–3 feet).

5.2 Vertical Cable Installation

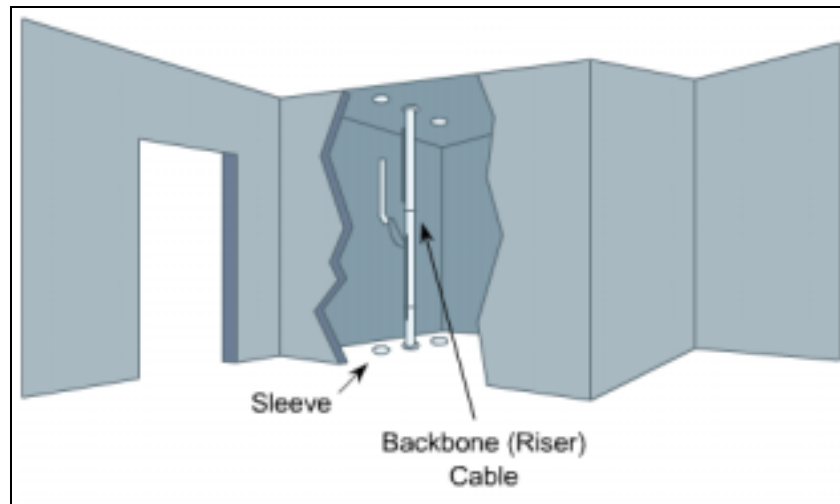

Figure 1 A Typical Riser

Vertical cable installation can include network distribution cables and backbone cables. Although backbone cables may be pulled horizontally, they are considered part of the vertical distribution system. Network distribution cables are part of the horizontal distribution system.

Most vertical installations are installed in conduits, in conduit sleeves through the floors, or in slots cut through the floor. A rectangular opening in the floor is referred to as a slot or a pipe chase. Risers are a series of holes in the floor, typically 10 cm (4 inches) in diameter, possibly with conduit sleeves installed. A typical riser is shown in Figure 1. The conduit sleeves may protrude up to 10 cm (4 inches) above and below the floor. Not all risers are stacked directly above one another. Therefore, riser alignment should be checked before the rough-in phase.

Vertical cable installation takes place either from an upper floor to a lower floor or from a lower floor to an upper floor. It is usually easier to pull cables from an upper floor to a lower floor since gravity assists in the effort. Since it is not always possible to bring large reels of cable to upper floors, there are times when vertical cables must be pulled from a lower floor. When pulling downwards, mechanical aids such as winches or cable pullers (also known as a tugger) are generally not needed, but reel brakes are required to prevent a cable free fall.

5.2.1 Cable winches

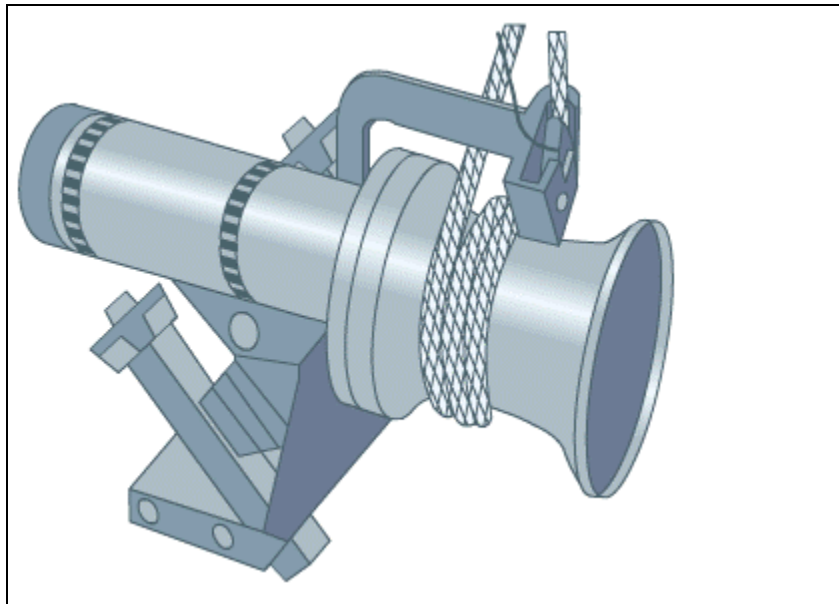

Figure 1 Cable Winch

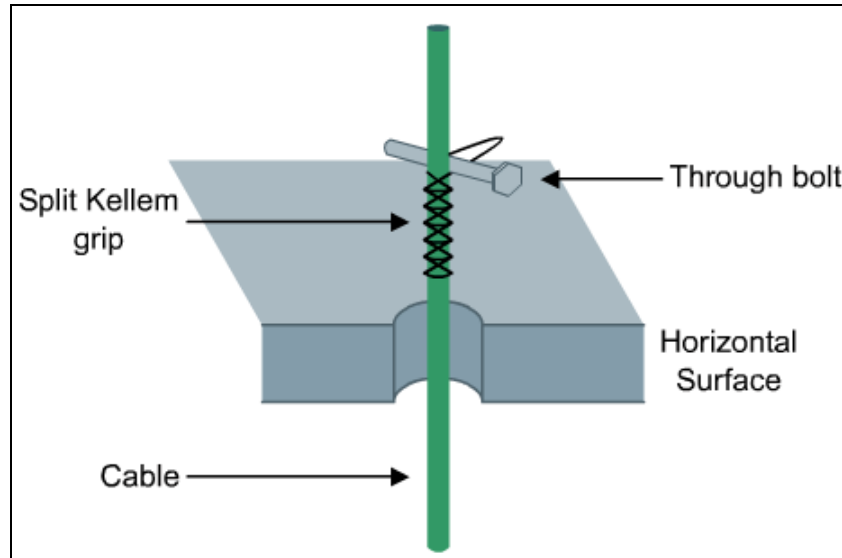

Figure 2 Split Kellerm Grip Secured with a Through Bolt

Cables in vertical pulls must be lowered carefully so that the cable does not spin off of the reel too quickly. A reel brake can help provide added tension.

A cable winch, which is shown in Figure 1, is often used for lifting cables. Since the equipment used for pulling cable can harm cable installers or onlookers, only members of the cable installation crew should be in the area. Pulling large cables with a cable winch creates a great deal of tension on the pulling rope. If this rope were to snap, someone in the area could be injured. Therefore, it is best to stand away from a pull rope that is under tension.

Cables can be ordered from the factory with a pulling eye installed. This is particularly useful for large, heavy pulls. If this is not possible, a Kellerm grip can be used. After the pull begins, it should be slow and steady. The pull should not be interrupted unless absolutely necessary. After the cable is pulled into place, the pull rope and winch will hold it until it is permanently fastened between floors using strut systems, friction clamps, or Kellerm grips secured with bolts, as shown in Figure 2.

5.2.2 Fastening vertical cables

One method for fastening vertical cables is to use a split wire mesh grip, or a Kellerm Grip, and a large bolt that is 25 to 30 cm (10 to 12 inches) long. It is important to use an appropriate grip size for the bundle of cables. The winch or the reel brake will support the cable, while a split wire mesh grip is installed at each floor. The bolt is installed through the loops in the grip. The cable is then gently lowered until it is supported by the grips. This is a permanent installation.

5.2.3 Cable installation tips

The following guidelines should be used for pulling cable:

- The staging area should be close to the first 90-degree bend. It is easier to pull cable around a bend when it first comes out of the box or off of the reel than it is near the end of the pull. The installer will be pulling the weight of all the cable pulled up to that point.
- Pulling lubricant should be used for long or difficult pulls to prevent damage to cables.
- The reel should be adjusted so that cable comes off of the top of the reel rather than from beneath it.
- If a fish tape becomes stuck in a conduit bend, rotate it a few turns while pushing.
- An additional piece of pull string should be pulled with the cable. This can be used as a pull string if additional cables are needed later. An additional pull string will eliminate the need to use another fish tape through this space.
- If cable must be coiled on the floor for a secondary pull, coil the cable in a figure 8 configuration to eliminate tangles when uncoiling. Use two safety cones or buckets as guides for coiling the cable.
- Supporting cables vertically through multiple floors can be a challenge. Run a steel strand or messenger between the floors, and anchor it at both ends. Vertical cable runs can be secured to this steel strand for vertical support.

5.3 Fire-Stops

The choice of cabling materials and how they are installed can greatly affect how a fire moves through a building, the type of smoke and gasses emitted, and the speed at which the smoke and flames spread. Using plenum rated cables where required, minimizing penetrations through firewalls, and using proper fire-stopping when penetration is unavoidable can reduce and slow the spread of smoke and flames. It is usually smoke that is lethal, not flames.

5.3.1 Firewall

A firewall is constructed out of special materials and techniques that will resist the movement of smoke, gasses, and flames from one area to another. Fire-rated walls also limit the spread of flames from the area where a fire originates to surrounding areas. This can protect building occupants and fire fighters from exposure to toxic gasses, smoke, and flames. Firewalls can also give the occupants extra time to evacuate the building.

5.3.2 Firewall penetrations

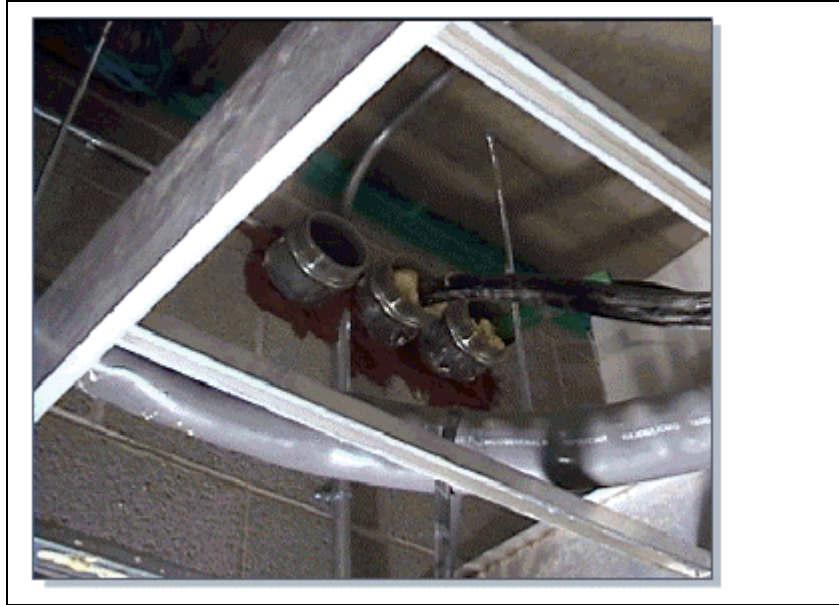

Figure 1 Typical Firewall Penetration

Several types of materials are used to construct firewalls. The most common material is drywall, or sheetrock. When applied floor to ceiling, each layer of this material can resist the spread of flame for approximately one-half hour. Two layers will provide protection for twice as long. Other common firewall materials include concrete blocks and poured concrete.

When cable must be pulled through a firewall, a hole must be drilled through the firewall. This is called a penetration and is shown in Figure 1. Penetrations can go all the way through the firewall. If the penetration only goes through one side of a firewall, it is called a membrane penetration.

After the hole is drilled, the penetration is usually sleeved by inserting a small section of conduit in the hole. The conduit must be large enough to hold the cables, with room for additional cables in the future. This conduit must protrude 30 cm (12 inches) on both sides of the wall. Cables are then pulled through the conduit. After the cables have been pulled through the conduit, the conduit must be sealed with an approved fire-stop material. This prevents fire from spreading from one section of a building through a hole in the firewall.

When cables are installed in an existing firewall penetration, the fire-stop material must be removed to clear space for the new cables. After the new cables have been pulled, the hole and conduits must be sealed with new fire-stop material.

5.4 Terminating Copper Media

Communications cables are color-coded to identify individual pairs. The color-coding is the same for all telecommunications cables in North America. The use of color codes ensures uniformity in identifying individual cable pairs. Each colored cable pair is associated with a specific number.

5.4.1 Four-pair color code

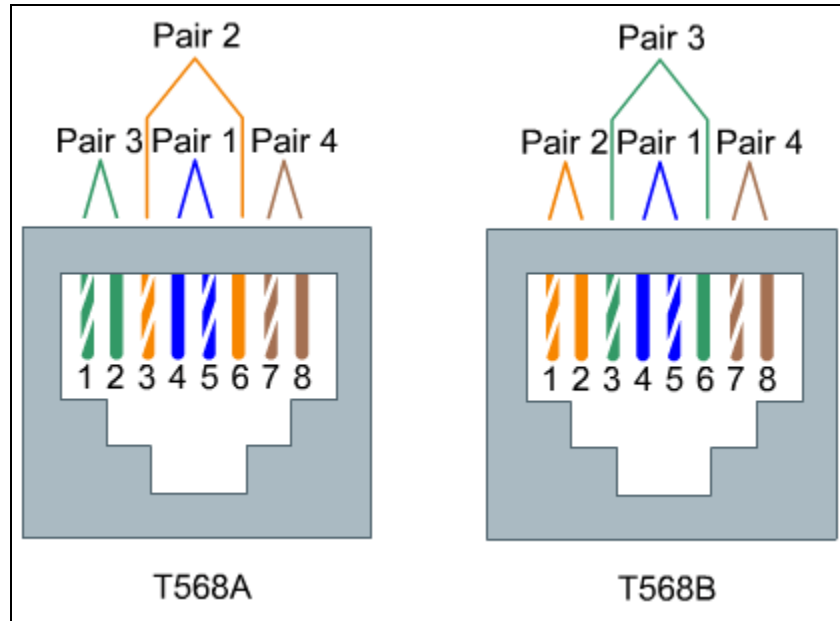

Figure 1 TIA/EIA T568A and TIA/EIA T568B Wiring Schemes

For most voice and data cabling, UTP cables are used. These cables have four pairs of twisted wires in each cable. The four-pair color code is as follows:

- Pair 1 – White-Blue/Blue
- Pair 2 – White-Orange/Orange
- Pair 3 – White-Green/Green
- Pair 4 – White-Brown/Brown

Pair 1 is always positioned on pins 4 and 5 in an eight-pin jack or plug. Pair 4 always appears on pins 7 and 8 on an eight-pin jack or plug. The other pairs have different appearances depending on the color scheme in use. The different wiring schemes are shown in Figure 1.

Either T568A or T568B should always be used for this wiring scheme. A new wiring scheme should never be created since each wire has a specific purpose. If the wiring is not correct, the devices on

both ends will not be able to communicate or they will experience severely degraded performance.

If the installation is in a new building, whether to use T568A or T568B is likely to be dictated by contract. If the choice is left to the installers, use whatever scheme is most popular in the area. If there is existing wiring in the building that is either T568A or T568B, follow the existing scheme. Remember that every installer on the team must use the same wiring scheme.

Occasionally there is some confusion over pair numbers and pin numbers. A pin is a specific location on a plug or a jack. The colored pairs are always the same. For example, pair 2 is always the white/orange pair. On an RJ-45 jack, however, pair 2 may connect to pins 3 and 6, or to pins 1 and 2, depending on whether T568A or T568B is used.

5.4.2 RJ-45 plugs and jacks



Figure 1 Panduit RJ-45 Jack

RJ-45 jacks are eight-conductor jacks that are designed to accept either RJ-45 plugs or RJ-11 plugs. An RJ-45 jack is shown in Figure 1. Jacks should be wired to the T568A or T568B standard.

RJ-45 plugs have eight pins that will accommodate up to four pairs of wires. As with RJ-11 plugs and jacks, pair 1 is always terminated on the center pins, which are pins 4 and 5. Pair 4, or the white/brown pair, is always terminated on pins 7 and 8. Pairs 2 and 3 may differ depending on the wiring plan. If using T568B, pair 2, or the white/orange pair, terminates on pins 1 and 2. Pair 3, or the white/green pair, terminates on pins 3 and 6. If using T568A, pairs 2 and 3 are reversed. Therefore, pair 2 terminates on pins 3 and 6, while pair 3 terminates on pins 1 and 2.

The end of the horizontal cable in the work area is usually terminated with an RJ-45 jack unless a consolidation point or MUTOA will be used. In this case, the horizontal cable will be terminated directly to the consolidation point, or by an RJ-45 plug when using a MUTOA. The other end of the cable will be typically be terminated in the telecommunications room by an RJ-45 jack when using modular patch panels, or directly to standard patch panel.

[Lab 5: Category 5e Jack Termination](#)

[Lab 6: Category 6 Jack Termination](#)

5.4.3 110-block



Figure 1 A Panduit 110-Block

110-blocks are high-density termination blocks that are used for either voice or data applications. 110-blocks come in many configurations, including the one shown in Figure 1. These blocks are designed to be stacked in different combinations to accommodate different size requirements. The 110 system includes wire management devices that also act as spacers between the blocks. Some 110-blocks have a special multipunch tool that can punch down up to five pairs of wire at a time. This tool should not be used on patch panels that contain printed circuit boards. The impact could damage the internal wiring.

[Lab 7: Terminating Category 5e to a 110-Block](#)

5.5 The Trim Out Phase

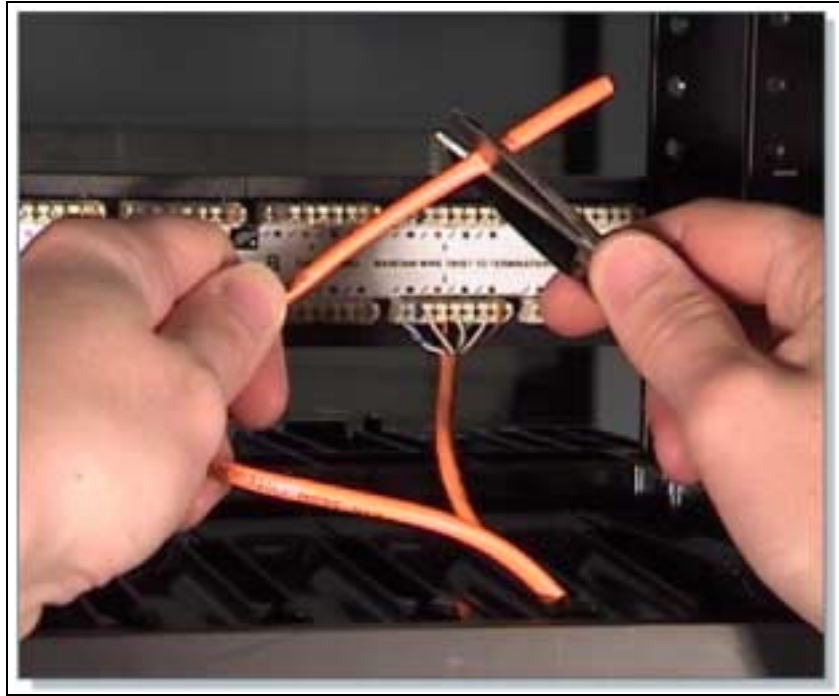

Figure 1 Cutting Cable to Length

In the rough-in phase of cable installation, excess cable was left at both ends of the cable run. These coils of cable are used to take up slack and facilitate later changes. The coils of cable are known as service loops. Service loops are discouraged by EIA/TIA standards. It is not uncommon to have 1 m (3 feet) of ends coming out of a wall jack at the end of the rough-in stage. A standard TR, where hundreds of cables are terminated, may have 2 to 3 m (6 to 10 feet) of ends.

Although this may seem wasteful, experienced installers know that an excess of cable provides more flexibility in cable routing and provides greater access to cables when toning and testing individual cables. New installers will commonly cut the cable too short. Excess cable can always be cut off, but a short cable cannot be extended. If a cable is too short, the only alternative is to pull another cable. This is a costly alternative in both labor and time.

If there is 1 m (3 feet) of cable coming out of the wall at the jack location, it is best to trim this to about 25 cm (10 inches). A new label should be applied to the cable about 15 cm (6 inches) from the end. The jacket is then stripped back about 5 to 7 cm (2 to 3 inches) to expose the individual twisted pairs. The completed jack termination should have no more than 1.27 cm (0.5 inches) of untwist in the cable pairs. Excess conductor length should be cut off at the final termination, as shown in Figure 1.

The jack is terminated with approximately 15 to 20 cm (6 to 8 inches) of cable coming out of the wall. This excess cable is carefully coiled into the wall or wall box when the jack is installed. This excess cable can be used to reterminate the jack at a later date. It can also be used to remove the faceplate and add another jack to the outlet. At workstation terminations, wires in the jack will commonly lose contact with the pins. This occurs because the patch cord to the work area is often pulled, kicked, or stretched by the workstation users.

5.5.1 Terminate or punch down



Figure 1 Removable Termination Blade

The termination of communications cables in a TR is sometimes referred to as punching down. Cables are also punched down on termination blocks mounted on the wall and at the rear of patch panels.

Wires are inserted into the appropriate locations on termination blocks. Then the punch down tool is placed over the wires. Depending on the type of termination hardware used, replaceable blades in the termination tool can be changed out to accommodate the termination type. A removable blade is shown in Figure 1. When pressure is put on the tool, spring tension increases to a point where a firing-pin type mechanism releases the energy stored in the spring. The wire is instantly forced between two insulation displacement connections and excess wire is cut off in the same operation. The connection is referred to as insulation displacement because the insulation is pushed out of the way by the contacting points on the terminal.

Insulation displacement connections provide a secure, gas tight connection. This means that the actual connection is not exposed to the atmosphere because the displaced insulation presses tightly against the block. This is necessary to provide long-term, corrosion-

free connections. Patch panels and 110-blocks are typically used for data networks. 110-blocks are also used for voice applications.

5.5.2 Wire management

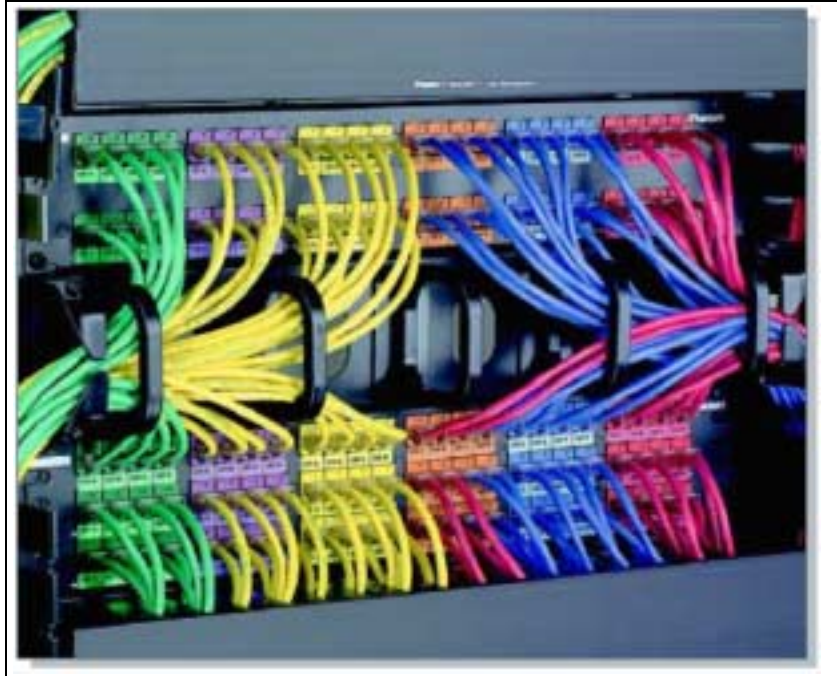

Figure 1 Panduit Wire Management

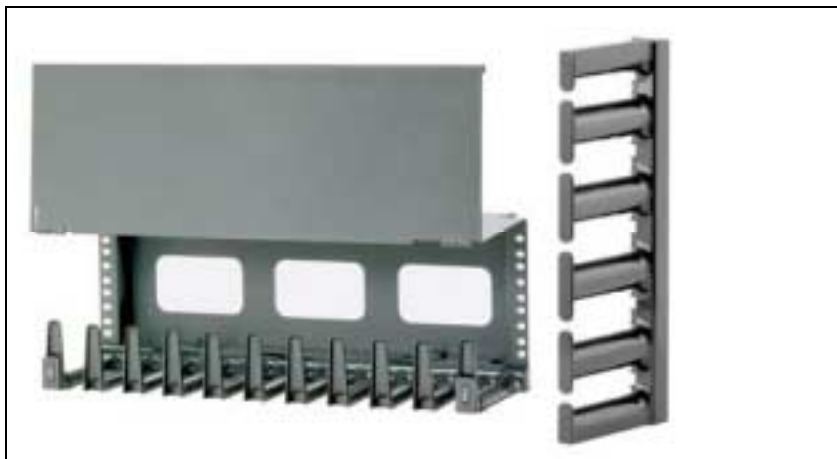

Figure 2 Panduit Wire Management



Figure 3 Panduit Wire Management

Some termination systems come with a built-in wire management scheme. 110-blocks use plastic troughs and spacers between blocks. Troughs can be used both horizontally and vertically. Rack mount installations incorporate a variety of wire management devices, as shown in Figures 1 - 3. Some use a combination of D-rings and troughs.

When purchasing cable management systems, consider the following:

- The system should protect the cable from pinching and it should prevent cables from exceeding the minimum bend radius.
- The system should be scalable so that it can handle more cables if necessary.
- The system should be flexible so that cables can enter it from all directions.
- The system should offer a smooth transition to horizontal pathways so cable is not damaged and does not exceed the minimum bend radius.
- The system should be durable enough to last as long as the cables and the equipment that is mounted on it.

5.5.3 Careful labeling

Labeling is another important part of a structured cabling system. Cables should be clearly labeled on both ends to avoid confusion. TIA/EIA-606-A specifies that each hardware termination unit should have a unique identifier marked on the unit or on its label. When identifiers are used at the work area, station terminations must have a label on the faceplate, the housing, or the connector. Most requests for proposals and specifications require computer-generated labels. These labels are permanent, legible, and more professional looking.

Use labels that will be easy to read for many years. Many network administrators include room numbers in the label information and assign letters to each cable that leads to a room. Many labeling systems for large networks also use color-coding.

To ensure that the labels are not rubbed off or cut off in the future, mark the cable several times at the free end, approximately 60 cm (24 inches) apart. After the cable is run, repeat the procedure at the box or spool end. Use electrical tape to keep all the cables tied securely together. Bind the cable ends and the end of a pull string together by tying some half-hitch knots around the cables with the pull string before taping the ends. Use a good amount of tape. If the string or cables pull out in the future, it could be expensive and time-consuming.

After pulling the cable along the selected route, bring it into the TR. Pull enough cable for the ends to reach each jack location, plus some excess cable to reach the floor and extend another 60 to 90 cm (24 to 36 inches).

Return to the spools of cable at the central point or TR. Use the labels on each spool as a reference. Then mark each cable with the appropriate room number and letter. Do not cut the cables unless they have a label. After following these steps, the networking media used for the horizontal cabling run will be labeled at both ends.

6 Finish Phase

Diagnostic tools are used to identify existing and potential problems in a network cabling installation.

Cable testers are used to discover opens, shorts, split pairs, and other wiring problems. After an installer has terminated a cable, the cable should be plugged into a cable tester to verify that the termination was done correctly. If a wire is mapped to an incorrect pin, the cable tester will indicate the wiring mistake. A cable tester should be included in every cable installer toolbox. After the cables have been tested for continuity, they can be certified by using certification meters.

6.1 Cable Testing

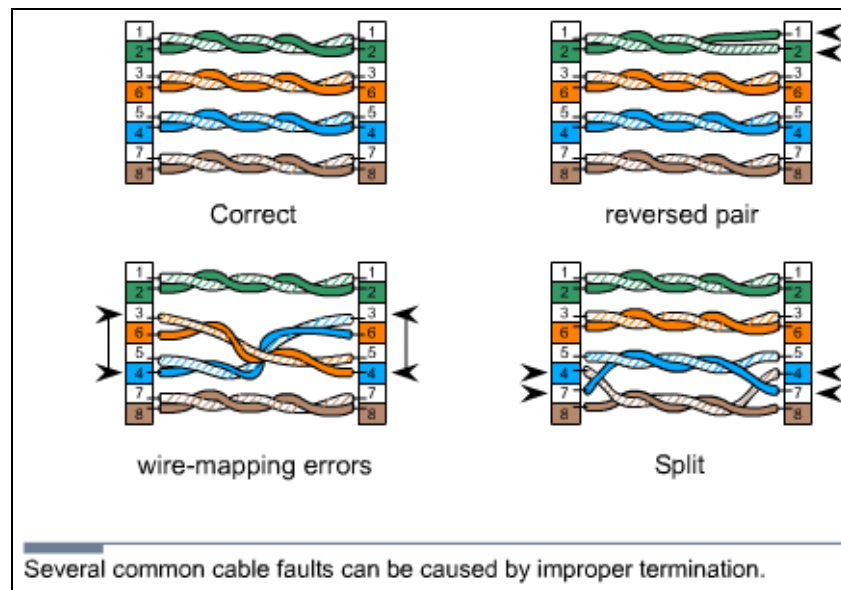

Figure 1 Wiring Faults

Testing is the most important step in the finish phase of cable installation. Testing verifies that all the wires are working properly so that the customer does not discover problems later. It is better to catch a problem before it becomes a major issue.

Tests relating to cable function are found in TIA/EIA-568-B.1. The following common cable faults are shown in Figure 1:

- **Opens** – Occurs when wires in a cable fail to make a continuous path from end to end. Opens are usually due to improper termination, breakage, or faulty cable
- **Shorts** – Occurs when wires in a cable touch each other and short the circuit

- **Split pairs** – Occurs when wires are mixed among pairs
- **Wire-mapping errors** – Occurs when wires in a multipair cable do not terminate at the appropriate points in the connector at the far end

Simple functional testing for opens, shorts, split pairs, and wire-mapping errors are usually performed from only one end of the cable.

6.1.1 Testing for shorts

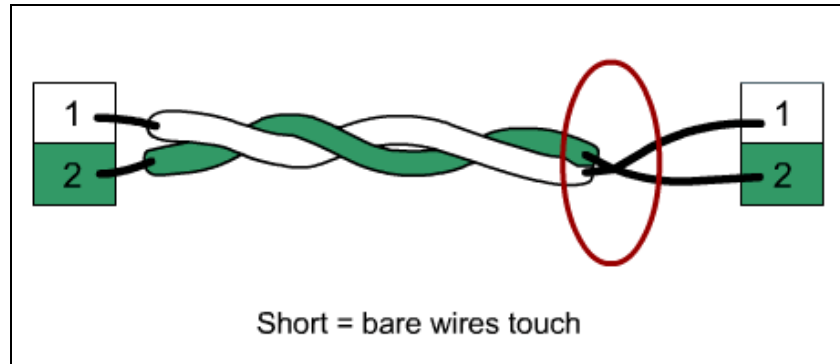

Figure 1 Short

A short is formed when two wires touch each other and create an undesired shortcut in the signal flow, as shown in Figure 1. This shortcut completes the circuit before the voltage reaches the intended target.

To determine if there is a short, measure the continuity or resistance between the wires. No continuity should be discovered, and there should be an infinite amount of resistance between them. Use an ohmmeter with a low-resistance scale to make these measurements. When a high-resistance scale is used, it may measure the body resistance of the installer when the wires are held to the probes. Some installers will create a small test fixture to avoid this problem. Many test probes can be fitted with slip-on alligator clips. These clips can hold one of the wires so that both leads are not touched at the same time.

6.1.2 Testing for reversals

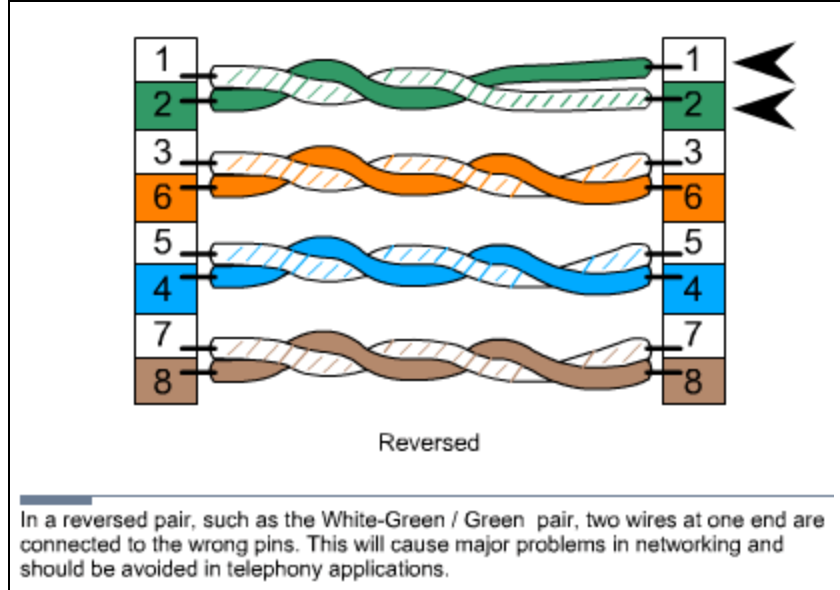

Figure 1 Reversal

A reversal occurs when one wire of a pair is terminated in the position of the other wire of the pair at the opposite end of the cable, as shown in Figure 1.

To repair a reversed pair in a cable, the cable end with the pair reversal must be terminated again.

6.1.3 Testing for split pairs

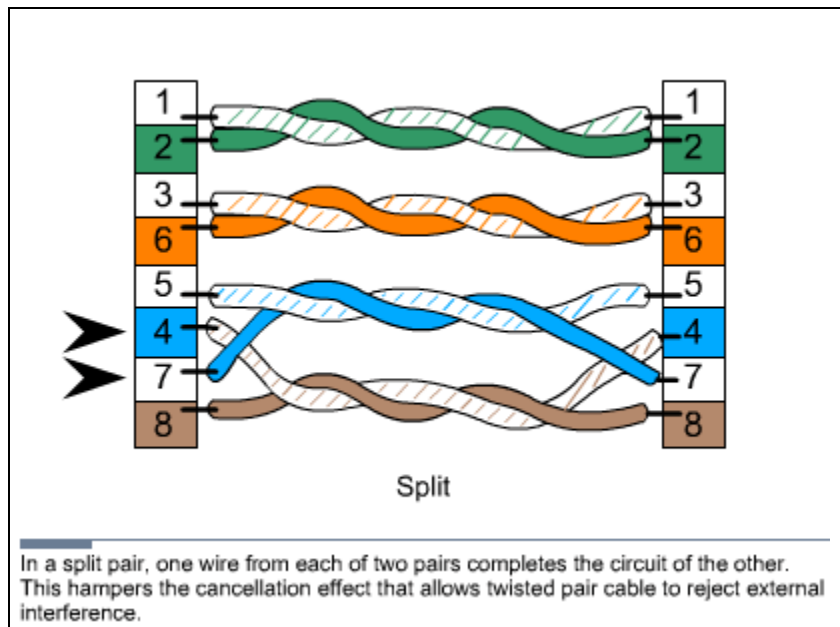

Figure 1 Split Pairs

Split pairs occur when wires are mixed among pairs, as shown in Figure 1. An ohmmeter can be used to test for splits. First, test the pairs for shorts. If none are found, place a short across each pair. The ohmmeter should detect a short. If an open is found, something is wrong. The pair is either split or open. A tone generator can then be used to determine whether it is split or open. High-end testers detect split pairs by measuring crosstalk between pairs.

A simple cable tester can also be used to check for split pairs. This type of tester uses LEDs that immediately notify the installer if there is a problem with polarity or continuity.

To repair a split, both of the connectors must be removed and the cable ends must be terminated again.

6.2 Time Domain Reflectometer (TDR)

A time domain reflectometer (TDR) sends a pulse down the wire and then monitors the electronic echoes that occur due to cable problems. TDRs will determine if there is a cable fault, and whether it is an open or a short. TDRs can also measure the distance from the meter to the fault. The signal is reflected back when it reaches the end of the cable, or anytime it encounters a defect in the cable. The signal speed is referred to as the nominal velocity of propagation. This is a known measurement for different cable types. When the tester knows how fast the signal travels, it can measure the length of the cable by measuring the amount of time it takes the signal to be sent and reflected back. A TDR readout is typically calibrated in feet or meters. If a TDR is properly adjusted and used correctly, it is an extremely efficient way to identify cable problems.

6.3 Cable Certification and Documentation

Testing is not the same as certification. Testing is for functionality and determines if the wire can carry the signal from end to end. Certification, or performance testing, is a statement about cable performance. Certification answers the following questions:

- How well does the signal travel down the cable?
- Is the signal free from interference?
- Is the signal strong enough at the other end of the cable?

6.3.1 Certification meter

Certification tests for functionality and performance. Structured cabling systems that adhere to installation standards must be certified. Certification meters perform all of the required performance tests to adhere to the ANSI/TIA/EIA-568-B standards. Most meters have an auto-test function that starts all of the required tests with the touch of a button. These meters store multiple test results, which are

downloaded to a computer. A test report is then generated and given to the customer. In addition to certification, these meters include diagnostic features that will identify problems and show how far these problems are from the end of the cable being tested.

Performance testing usually occurs at a designated test frequency. The frequency is selected to exercise the cable at a speed that will be part of its intended operation. For example, Category 5e cable is tested at 100 MHz and Category 6 is tested at 250 MHz. Performance testing is described in TIA/EIA-568-B. Modern testing hardware and software can provide both text and graphic output. This allows for easy comparisons and quick analysis.

The cable certification process forms a baseline measurement for the cabling system. When the contract is established, a certification standard is usually included as part of the contract. The installation must meet or exceed the specifications for the wire grade that is used. Detailed documentation is used to show the customer that the cabling has reached these standards. These documents are submitted to the customer.

The certification procedure is an important step in the completion of a cabling job. It demonstrates that the cables performed to certain specifications. Any future change in cable performance will need to be attributed to a specific cause. It will be easier to figure out what that cause is if there is documented evidence about the condition of the cables at an earlier point. Different grades of cable require different acceptable test results. Higher cable categories generally have higher manufacturing standards and better performance.

6.3.2 Certification tests

To pass certification, cables must meet or exceed the minimum test results for their grade. Many actual test results will outperform the minimum. The difference between the actual test results and the minimum test results is known as headroom. More headroom indicates that less cable maintenance will be needed in the future. These networks are more tolerant of poor grade patch cords and equipment cables.

The commonly used specifications include the following:

- **Specified Frequency Range** – Each cable is tested at a frequency range that will be used in daily service. A higher grade indicates a higher range.
- **Attenuation** – The amount of signal that a cable will absorb is a measure of its attenuation. Lower attenuation indicates higher-quality conductors and cables.
- **Near End Crosstalk (NEXT)** – This occurs when signals from one pair interfere with another pair at the near end of the cable. Crosstalk can affect the ability of the cable to carry

data. The amount of NEXT a cable must be able to tolerate is specified for each grade.

- **Power Sum NEXT** – When cables use all the conductors, the signals on one cable interfere with several pairs. To calculate the effect of these disturbances, the interactions of all pairs in the cable must be considered. The power sum NEXT equation measurement does this.
- **Attenuation-to-Crosstalk Ratio (ACR)** – This ratio indicates how much stronger the received signal is when compared to the NEXT or noise on the same cable. This measurement is also referred to as the signal-to-noise ratio (SNR), which also accounts for external interference.
- **Power Sum ACR** – When all of the pairs in a cable are used, the interaction between the pairs becomes more complicated. There are more wires are involved so there are more mutual interactions. The power sum equations help take this greater mutual disturbance into account.
- **Equal-Level Far End Crosstalk (ELFEXT)** – This is a calculated measurement of the amount of crosstalk occurring at the far end of the wire. If this characteristic is very high, the cable is not carrying the signals well and the ACR ratio is not well controlled.
- **Power-sum ELFEXT** – As with the other power sum measurements, interaction between multiple pairs in the same cable increase the complexity of ELFEXT characteristics. The power sum version of the measurements considers this.
- **Return Loss** – Some of the signal that travels down a wire bounces off imperfections such as impedance mismatches. It can be reflected back toward the sender and form a source of interference. This is referred to as return loss.
- **Propagation Delay** – The electrical properties of the cable can affect the speed of a signal. The value of this delay is used to perform certain measurements, such as time domain reflectometry. Propagation delay for a cable is usually specified as a maximum allowable amount of delay, in nanoseconds.
- **Delay Skew** – Each pair in a cable has a different number of twists. Signals that enter the cable at the same time will probably be slightly out-of-sync when they get to the far end. This is referred to as delay skew. Sloppy termination can magnify this problem if the cables are asymmetric with respect to the connector pins. A difference in propagation delay between the wires in a cable pair can also cause delay skew.

6.3.3 Link and channel testing

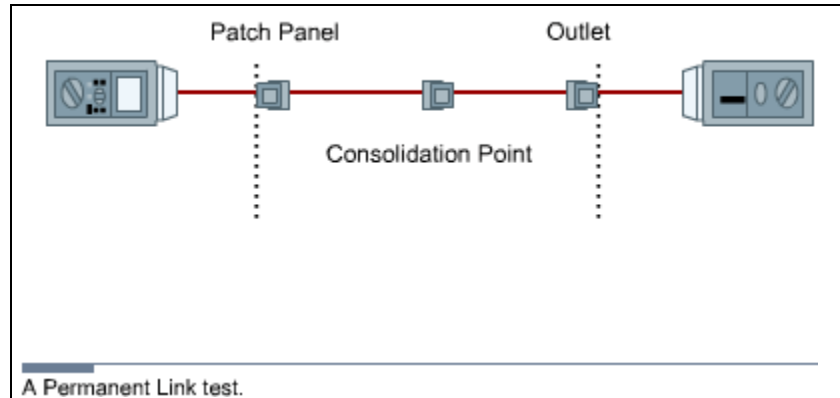

Figure 1 Permanent Link Test

The two methods used when testing are the channel test and the link test. The channel test goes end-to-end from the workstation or telephone to the device in the TR. The channel test measures all of the cable and patch cords, including the line cord from the jack to the user equipment and the patch cord from the patch panel to the communications equipment. The link test only tests the cable from the wall back to the patch panel in the TR. There are two types of link tests. The basic link test measurement starts at the field tester and ends at the field tester remote unit at the other end of the link. The permanent link test excludes the cable portions of the field test units, but includes the mated connection where the cable is connected to the adapter cable at each end, as shown in Figure 1. The permanent link test also allows for a consolidation point. This is desirable for open office cabling installations and is therefore more practical.

The only accepted test is the permanent link test. The channel test has been officially eliminated by TIA/EIA-568-B.1.

6.3.4 Certification tips

The interpretation of test results is just as important as the detection of problems. Installers can learn how to interpret test results by using test equipment on known good wires and circuits. This will provide a knowledge base of how to properly use test equipment and how the test results should appear when the circuits function properly.

To gain experience with troubleshooting and problem identification, create cables with specific problems. Observe how testers react to these problems. Practice identifying these problems based on test results for randomly chosen cables. The time invested in education will help the installer identify and fix future problems quickly.

6.3.5 Professional certification documentation

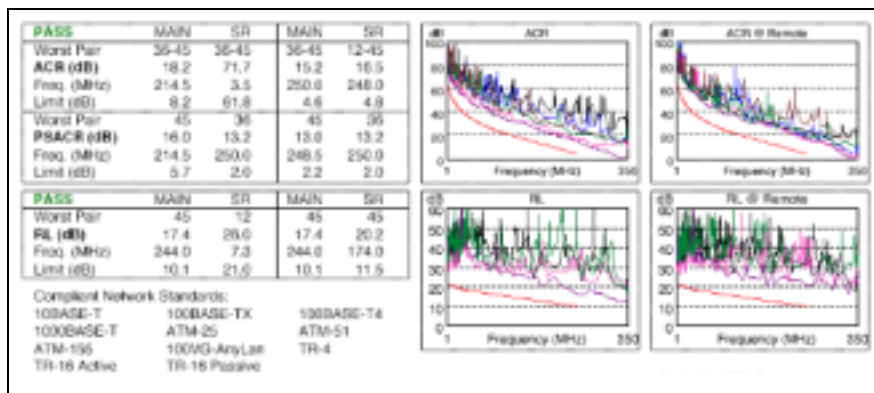

Figure 1 Cable Certification Documentation

Many cable certification tools can export results in a database format. This can be used in a personal computer to produce high-quality documents, as shown in Figure 1.

Installation software is generally provided with sophisticated certification testers. The software will allow the contractor to present the test result to the customer in an orderly manner. The software eliminates the need to manually enter the results in a spreadsheet. Software packages store test results as either pass or fail. When deficiencies are found and corrected, items are retested and presented to the customer. Customers generally want both an electronic copy and a paper copy of the test results.

Documentation must be accessible to be useful. Electronic delivery ensures that the results are always available when needed. A paper set of both the as-built documents and the certification results should be provided to the customer. Installers should retain a copy in their permanent records.

Certification documentation becomes very important when there is a question about the quality or accuracy of the wiring job. It shows that on a specific date, the wires existed in a particular order and could carry signals at a specified level of quality. Changes in the ability of the cable to move signals over time can be determined by comparing current tests to previous results.

Unexpected obstacles, change orders, and last minute equipment upgrades can affect the documentation. Therefore, the documentation that was used to construct a network wiring system may not be representative of the system that was actually constructed. Anytime a modification is made to the wiring system, it is important to know what is happening in the system. Otherwise, the changes could have unpredictable effects. As-built documents can help avoid this kind of trouble. Always create change documents before any changes are made.

6.4 Cutting over

Cutting over is the term used for the transfer of existing services to a new cable system. It is also used for the installation of new equipment on a newly installed cable system.

6.4.1 Cutover guidelines

Successful cutovers require careful planning, organization, and attention to detail. When cutting over, use the following guidelines to ensure success:

- Keep detailed records of the installation. These records will verify that all cables have been installed in the correct locations.
- Test every cable that is installed.
- Develop accurate cut sheets. Cut sheets are a chart of circuits and the cables on which they operate. The installation supervisor normally develops cut sheets with information received from the customer.
- Schedule the cutover when it is most convenient for the customer. Since cutovers usually require taking some systems offline, they are often scheduled late at night or on weekends.

6.4.2 Removing abandoned cable

According to the National Electrical Code, edition 2002, all abandoned cables must be removed when certain criteria defined within the code are met. Currently, the customer and cable installation contractor decide whether or not the cost involved in removing cables is justified. The customer and contractor must be sure to adhere to the local code. Always check with the local authority and discuss the details with the customer before beginning the retrofit.

Before removing any abandoned cable, first verify that there are no live circuits on the cable by using a multimeter or a telephone test set. Remove the abandoned cable carefully to avoid damaging ceiling tiles or dropped ceiling support members.

7 The Cabling Business

As with most jobs, the appearance and demeanor of cable installers can affect how customers, bosses, and fellow employees perceive them. The choices a cable installer makes on the job may result in promotions or terminations. As an employee, the cable installer becomes a representative of a company. Therefore, a professional appearance and demeanor should always be maintained.

When working on a job, use the following guidelines:

- Respect the job site. Be careful to avoid causing damage. Clean up all messes immediately if they affect other workers or clean them up at the end of the day.
- Wear clean and neat work clothes to the job site.
- Arrive at an agreed upon time. Punctuality is important.
- Determine the acceptable noise level. Avoid playing music, whistling, singing, or shouting if working on a retrofit project while business is being conducted.
- Treat customers, building occupants, coworkers, and bosses with respect.

7.1 Site Survey

The site survey, or project walk through, is one of the most important steps before preparing a cost estimate for a project. It allows the contractor to identify any issues that may affect the installation. Drawings and specifications supplied by the customer may not indicate potential problems or complications.

A sketch of the project should be created during the walk through. The sketch can be used to identify problem areas when performing the estimate.

There are several key questions to ask during a site survey:

- Are there plenum-ceiling areas?
- Is there a staging and storage area for materials?
- Are special work hours required?
- Are there special safety requirements? This is particularly relevant in factory environments.
- Which walls are firewalls?
- Is there asbestos in the building?
- Will the customer supply spare ceiling tiles in the event of breakage?

- Are there special labor issues to be considered?

7.1.1 Requirement documents

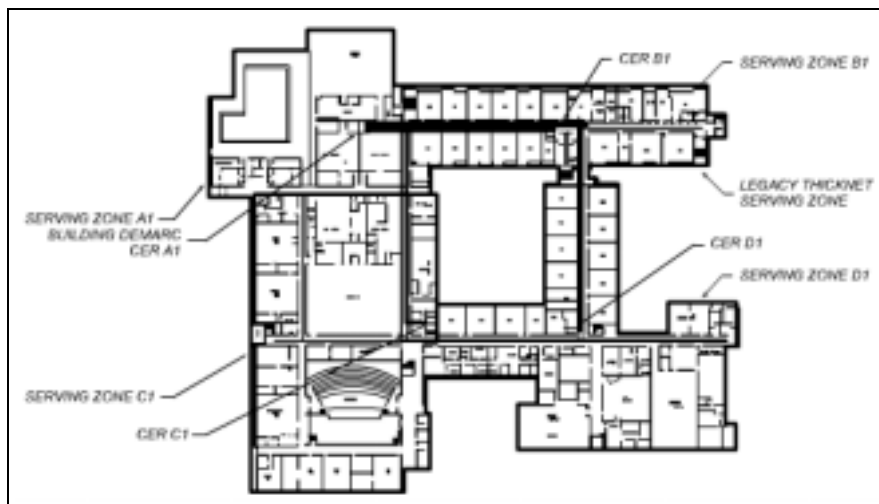

Figure 1 Typical Building Blueprints

Blueprints are scaled drawings that provide the distance information required to determine the length of cable runs, as shown in Figure 1. Blueprints should also show service outlet locations and TRs. Some blueprints also include available paths or routing information. However, routing information is generally obtained through a site survey. Most structured wiring systems specify a minimum of two four-pair cables per location and many customers specify more. This information should be duplicated in the specifications for the project.

Count outlet locations and measure cable distances on a blueprint. These are referred to as take offs. Take offs require a great degree of accuracy since they are used to determine the material requirements for a bid. Many automated measuring devices are available to help automate the process and minimize errors.

7.1.2 Installation icons and symbols

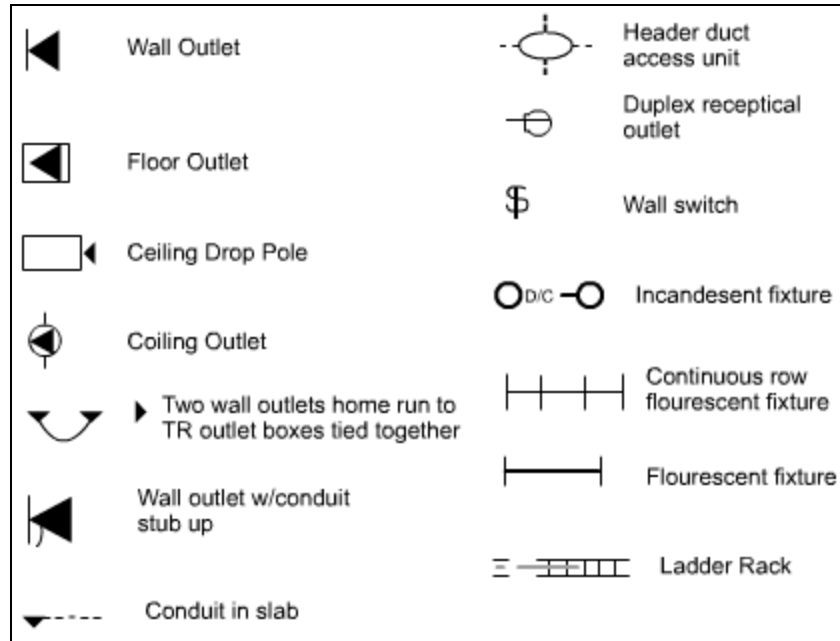

Figure 1 Cabling Installation Icons

Standard icons and symbols are used on blueprints and schematics to identify cable runs, raceway types, outlets, and jacks, as shown in Figure 1. These icons provide a uniform method to graphically identify requirements on a blueprint.

7.1.3 Drawing types

- ◆ T0 - Campus or site plans - Exterior pathways and inter-building backbones
- ◆ T1 - Layout of complete building per floor - Serving zone boundaries, backbone, and horizontal pathways
- ◆ T2 - Serving zones drawings - Drop locations and cable labels
- ◆ T3 - Communication equipment rooms - Plan views of racks and elevations of walls
- ◆ T4 - Typical detail drawings - Faceplate labeling, fire-stops, and safety features
- ◆ T5 - Schedules (cabling and equipment spreadsheets) for cutovers

Figure 1 Types of T Telephone Drawings

Construction blueprints follow a standardized format. Drawings are grouped according to category and are labeled with a prefix that identifies the category. For example, all drawings for the electrical system are grouped together and have the prefix E. Architectural

sections begin with the letter A and all plumbing begins with a P. Telephone and data are usually grouped together and are represented on the T drawings, as shown in Figure 1. Additional drawings, such as furniture plans, will either be found in the A drawings or in a miscellaneous category.

The estimator will need the following drawings:

- Site plan for an overview of the project
- Floor plans
- T drawings for telephone placement
- E drawings for electrical reference
- Furniture plans to help determine outlet placement
- A drawings to discover architectural features and available pathways

Design documents include a narrative about the project. This narrative may describe the functionality of the cabling system. For example, it may indicate that the system must support 1000BASE-T or gigabit Ethernet on twisted pair.

Most design documents include trade jargon and acronyms unique to an industry or the system being installed. The estimator should understand all terms in the design document. Glossaries of terms and acronyms are available on the Building Industry Consultants Service International (BICSI) website.

Design documents also specify the requirements of the system and the types of materials that will be used. Information about the number of cables required per information outlet or jack will also be supplied. Design documents will also describe testing specifications, labeling specifications, and formats.

7.1.4 Schematic diagrams

Schematic drawings are not to scale. They are used to depict connectivity, or the way things are connected. A typical schematic will show the main TR or MC and the IC. It will also show the type and size of cables between these points. Most schematics will not detail the actual terminations at these locations or show individual cable runs to information outlets or jacks. These schematics will include cable runs to specific types of equipment like servers or other major components that are used in a project.

7.2 Labor Situations

Every cable installation company must deal with labor issues. Some of these issues can cause problems with unions. Installation companies must be aware of the rules and regulations that apply to unions and licensing.

7.2.1 Unions

Some projects may require the use of union labor. Unions are organizations that represent workers. The use of union labor is more common for, but not limited to new construction projects. The use of union labor may be part of a contract. If a customer clearly states that union labor must be used, the contractor must use union labor.

Other labor situations may dictate the job classification and the work that is allowed. In a union environment, supervisors are normally not allowed to perform any installation work and cable installers may not be allowed to install raceway. Sometimes, cable installers can install raceway up to a certain size or a certain length and electricians must install anything beyond that. These rules are defined by a union agreement, which may be determined by unions of different trades.

7.2.2 Contractor licenses

Some countries do not require contractors to be licensed. In the United States, contractor license rules vary for different states. Some states require a contractor license number on all advertising, business cards, and letterhead. Contractors that operate without a required license may be fined or lose certain rights. For example, they may not be able to file a lien if their customers do not pay for services rendered.

Licensing requirements include technical knowledge, business knowledge, and knowledge of the labor laws of the state. Contractors are responsible for knowing if they must be licensed in a particular state or country.

7.3 Contract Revision and Signing

After all of the negotiations are complete, the contract must be revised to reflect any agreed-upon changes. The customer and the contractor must then review the contract in detail. Contract negotiation is a verbal event that is used to ensure that all intentions are accurately represented in the written document. Any changes to the contract while the project progresses are often addressed in amendments to the contract. Amendments are agreed to and signed by both the customer and the contractor.

The contract must be signed to become a valid agreement. No materials should be ordered and no work should begin before the contract is signed.

A template can be created for common documents such as change orders. These templates can be brought to the project site and the information can be entered during the initial meeting or a walkthrough.

Any changes to a project after it has been started will require a written change order. No changes to the original plan should be

started by verbal instructions only. Change orders that result in extra work should include the cost of the extra labor and materials. If this is not possible, the change order should state that the customer agrees to pay for extra work.

7.4 Project Planning

The planning phase of a project may begin before a formal contract is signed. Information about bidding and estimating is assembled, special requirements are noted, resource allocations are made, and a final review of the RFP takes place to make sure that all of the components are addressed.

The following steps should be taken in this planning phase:

- Select the project manager or supervisor.
- Select crews based on the project size, skills required, and time allowed for completion.
- Identify and schedule subcontractors.
- Create a material delivery schedule.
- Make provisions for waste disposal.

7.4.1 Suppliers

The estimator will normally select suppliers based on cost, delivery, and service. The estimator will use the following questions to determine the total cost of material:

- Does the price include shipping?
- Does the supplier have a history of delivering goods on time?
- What is the policy for returned goods?
- Can the supplier provide cut sheets and engineering drawings in a timely manner?
- Can the supplier provide technical advice and support?

7.4.2 Ordering materials

After the contract is signed, written purchase orders should be used to order materials from suppliers. Purchase orders should include a description of the material, the manufacturer part number, quantity, price, delivery date, and delivery location.

Generally, the lowest cost supplier that can provide the specified cable and equipment will be selected. Shipping costs must be considered to determine the lowest cost. Supplier pricing should include a guarantee that the pricing will not change for a specified period of time. Most suppliers will guarantee pricing for at least thirty

days. The supervisor or lead contractor must make sure that there are no unapproved substitutions, in an effort to reduce costs.

7.5 Final Documentation

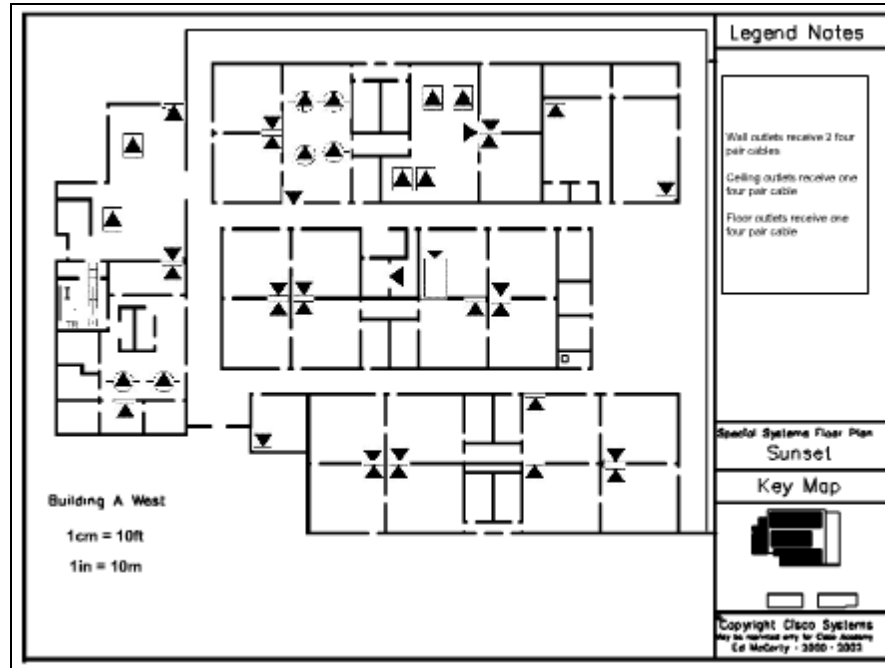

Figure 1 As-Built Drawings

PUNCH LIST		
<p>A punch list is a record of all items within a project that the contractor must correct or complete to the satisfaction of the homeowner before the job is considered finalized.</p> <p>Prior to the project closeout and final payments, homeowner and contractor or architect should jointly conduct a project walk-through to observe all items that need correcting or completing.</p> <p>All parties understand that when the homeowner agrees that the punch list details itemized below have been completed to his or her satisfaction, the project is entirely complete and all outstanding payments are due to the contractor and/or architect.</p>		
Punch List Items	Date	Approved

Figure 2 Typical Punch List

It is important to provide as-built drawings to the customer, as shown in Figure 1. These drawings show cable routes, termination points,

and cable types as they are installed. Some cables may not be installed as originally planned if obstructions or problems are encountered. Typical changes include adding or deleting cable runs or outlets, or routing cables by a different path.

As-built drawings are not created until all cables are placed, all jacks are installed, and all cables are terminated. The drawing can begin during the final testing phase. However, any changes or additional work must be accurately reflected in the drawings.

Floor plans, furniture plans, or T drawings are usually used as the basis for as-built drawings. The contractor is not required to redraw building plans for as-built drawings. The contractor draws all cable runs, terminations, and outlets and supplies all labeling information.

The punch list is the checklist that the customer provides the contractor with when the contractor considers the project complete, as shown in Figure 2. The punch list includes the following items:

- Uncompleted items, such as missing outlets or cable runs
- Unsatisfactory items, such as cables that are not fastened to ladder racks or outlets that do not work
- Clean up items, such as debris left in the corridor

These items must be corrected prior to final approval and acceptance of the project. After the items on the punch list are completed, payment is expected.

Lab 1: Examination of Termination Types

Objectives

- Review wiring standards T568A, T568B, and RJ-45 USOC.
- Terminate the ends of a Category 5e cable.

Background/Preparation

Bell Telephone established the technique for terminating twisted-pair cabling. This technique, called the Bell Telephone Universal Service Order Code (USOC), logically organizes the wires into a modular plug. Basically, the first pair goes into the center two pins and the other pairs follow from left to right, splitting each pair down the middle. This is appropriate for voice technologies, but it can cause trouble for data, because it separates the wires in the pairs, causing crosstalk. For this reason, the T568A and T568B wiring standard were developed. These wiring patterns keep the wires in each pair together, improving cable performance.

In this lab, identification, preparation, and termination of Category 5e cable will be learned using the two most popular wiring schemes found in the ANSI/TIA/EIA standards, T568A and T568B.

Work in teams of 2 to 4 people. Each team will need four Category 5e cables with a minimum length of 1 m (3 feet) each. The following resources will be required:

- 4-5 m (13-16 ft) Category 5e cable
- Pan-Plug modular plugs
- Pan-Plug crimp tool
- Wire stripper tool
- Scissors
- Wire snipping tool
- Wire prep tool
- Safety glasses
- Fluke 620 cable meter or LinkRunner

Optional: USOC wiring schematic

URLs

<http://www.panduit.com/>

<http://www.tiaonline.org/>

Safety

Wear safety glasses at all times during this lab.

Step 1 Removing the Cable Sheath

- a. Use a ruler and measure 8 cm (3 inches) from the end of the cable. Put a mark on the cable.
- b. Use the wire stripper tool to carefully score the outer sheathing of the cable without fully cutting through to the conductors. Cut off as close possible to the marked length and remove the cut sheathing.

Do not nick any of the insulators.

Note: Notice on the stripping tool that there is a minimum or maximum cutting direction. Use the minimum cutting direction. Do not make more than two 360-degree turns with this tool.

Step 2 Fan the Four Pairs

- a. Untwist each of the cable pairs. Take care not to untwist more than is needed, as the twisting provides noise cancellation.
- b. Keep the individual pairs grouped together for ease of identification. This is helpful because some tip wires may not have any visible trace of color and may appear to be solid wires.

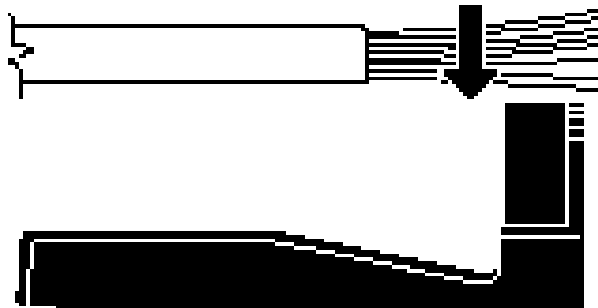

- c. Use the wire prep tool and insert the conductors individually in the proper sequence using the T568A or T568B wiring scheme.

Note: The top of the arrow in the above diagram will be pin 1 and 2, White/ Orange and Orange.

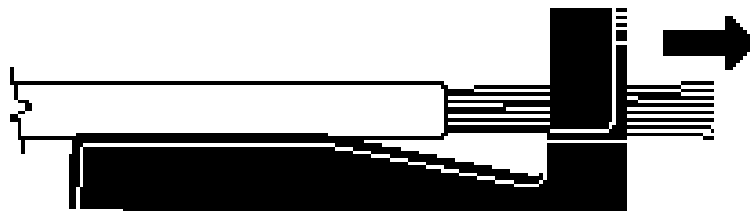

- d. Pull the conductors until cable jacket is at the conductor retention slot.

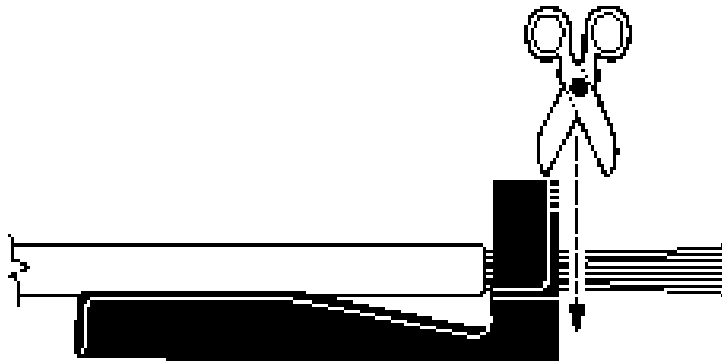

- e. Trim the conductors flush with the wire snipping tool.

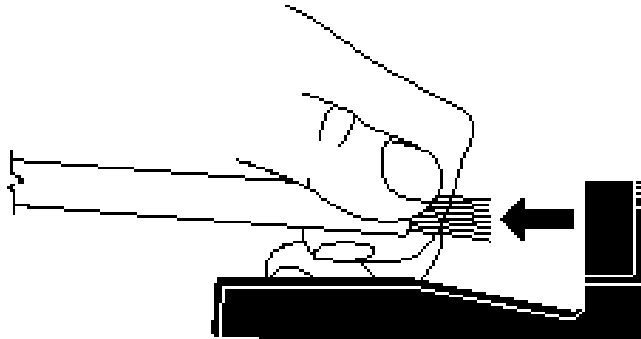

- f. Remove the cable from the conductor retention slot, keeping the conductors held in position by placing thumb and forefinger at the cable jacket end.

Step 3 Terminating a Plug with T568A Wiring Standard

T568A Schematic

Pin#	Pair#	Function	Wire Color
1	3	Transmit	White/Green
2	3	Transmit	Green
3	2	Receive	White/Orange
4	1	Not used	Blue
5	1	Not used	White/Blue
6	2	Receive	Orange
7	4	Not used	White/Brown
8	4	Not used	Brown



Note: Shown here is a diagram of an RJ-45 jack. Notice that the plug will fit with the key toward the bottom of the jack. Positioning the plug with the key pointed away from you when inserting the conductors will ensure that pin 1 will start on the left and proceed to pin 8 on the right.

- a. Terminate one side of the cable using the T568A standard.

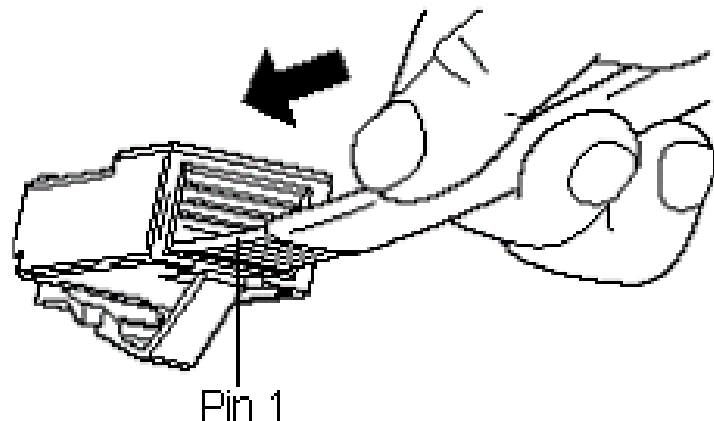

- b. Apply a slight downward pressure as the conductors are inserted. Apply slight pressure until they are fully inserted and under the plug contacts at the top of the plug.

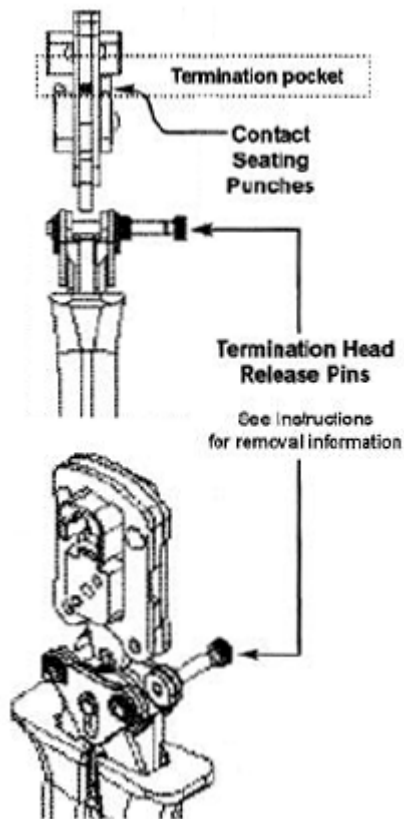

Place the plug into the die until it clicks.

- c. Complete the termination by closing the handles fully and then releasing them.

Step 4 Terminating a Plug with T568B Wiring Standard

- a. Repeat Steps 1 through 3.

T568B Standard

Pin#	Pair#	Function	Wire Color
1	2	Transmit	White/Orange
2	2	Transmit	Orange
3	3	Receive	White/Green
4	1	Not used	Blue
5	1	Not used	White/Blue
6	3	Receive	Green
7	4	Not used	White/Brown
8	4	Not used	Brown



- b. Once both ends of the cable have been completed, have a team member review the wiring standards to ensure that the plugs are correctly terminated.

Step 5 How To Decide Which Wiring Standard To Use

- a. When deciding which wiring standard to use, ask these questions:
 - Does the job specification require a certain wiring standard?
 - Has it already been established by the existing cabling?
 - Does the new wiring match the existing wiring?
 - Has the customer specified a wiring standard?
 - Have patch panels already been purchased for the job? If so, they will probably be either T568A or T568B. The jacks should be wired to the same standard as the panels.
- b. If none of the previous factors apply, either T568A or T568B may be used. It is important to ensure that the workstation connectors and the patch panels are wired to the same standard. In the United States, T568B is commonly used in commercial installations, while T568A is the standard in residential installations.

Step 6 Testing

- a. Use the Fluke 620 cable meter or LinkRunner to test the jack installation.

What are the results of the test?

- b. Are the results exactly the same when the second jack is tested?

c. Why or why not?

Step 7 Clean Up

Ensure that all tools are properly stored, and that all trash and debris has been removed from the work area.

RJ-45 USOC Schematic

Pin#	Pair#	Wire Color
1	4	White/Brown
2	3	Green
3	2	White/Orange
4	1	Blue
5	1	White/Blue
6	2	Orange
7	3	White/Green
8	4	Brown

USOC is an old standard used for voice cabling. For phones with one or two lines, which use pins 4/5 and 3/6, T568A or T568B will work just as well as USOC. However, for Ethernet, pins 1/2 and 3/6, USOC will not work. An Ethernet NIC trying to transmit on pins 1/2 will not work because 1/2 is not a pair, they are not the same color and not twisted together. The USOC code is not recognized by the Standards, however it is common in the termination of T1 circuits.

Lab 2: Terminating a Category 5e Cable on a Category 5e Patch Panel

Objectives

- Terminate a Category 5e cable on a Category 5e patch panel.
- Proper use of the 110-punch-down tool.
- Proper use of the cable stripper.

Background/Preparation

A Category 5e patch panel is a device that is used to terminate wires in a central location. Cables from local data and voice networks are collected in one patch panel, and cables from the outside are collected in a separate panel. These two panels provide a way to connect the two collections of wires in order to supply connectivity from outside the building all the way to the desktop. This system of wire management allows for organization and quick changes.

In this lab, a Category 5e cable will be terminated on a patch panel. The other end of the cable will be terminated on a 110-connection block.

The instructor or lab assistant will designate the location of the punch-down for each student at the top of this sheet indicating the rack, row, and position on the patch panel. Work in teams of 2 to 4 people. The following resources will be required:

- Category 5e patch panel
- 1.2 m (4 ft) of Category 5e UTP cable
- Wire stripper tool
- Wire snipping tool
- Impact tool with 110 cutting blade
- C4 clips
- 110 to RJ-45 adaptor cable
- Fluke 620 or LinkRunner
- Safety glasses

URL

<http://www.panduit.com>

Safety

Remember to always wear safety glasses when punching down wires. Always be conscious of the task being performed to avoid accidental cuts.

Step 1 Cable Preparation

Remove enough of the sheath to terminate the cable on the patch panel.

Step 2 Insert the Conductors

- a. Fan out the conductor pairs without untwisting the wires at all.
- b. Follow the label on the rear of the patch panel. Cables will be terminated as T568B.
- c. Make sure to have 8-10 cm (3-4 inches) of extra wire past the termination point and split a twist on the colored tip. The tip color goes to the left and the ring color goes to the right. This will ensure that the twisting continues up to the point of termination. It is very important that the twists in the wire remain as tight as possible up to the point of termination.

Note: The maximum untwist length for Category 5e cable is 1 cm (0.5 in).

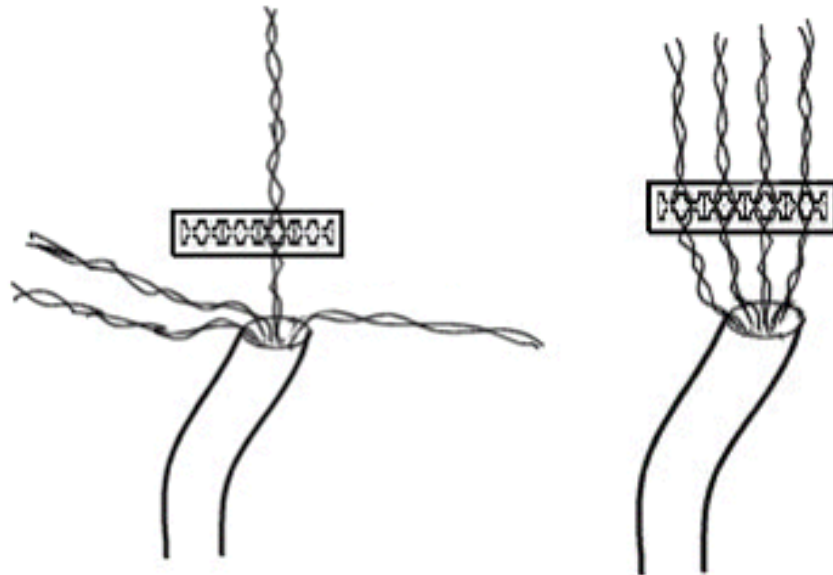

- d. To make sure the termination of the cable looks professional, it is best to begin the insertion of the conductors with the center pairs and work towards the outside termination points. This will provide the outside wire pairs a minimal and equal amount of exposure.

Step 3 Punch Down

Note: If the patch panel is punched down on too hard, the circuit board inside may be damaged. The single wire impact tool with the 110-blade should only be used for this application. The impact tool

should be set on the “lo” setting. Never use the multipunch tool when terminating on a patch panel.

- a. Position the impact tool over the wire with the blade facing toward the end of the wire and press firmly on the impact tool until it clicks. Do not hit the tool with the hand to punch down the wires. With the impact tool set to “lo”, it may be necessary to punch the wire two or three times to insure a proper termination.
- b. Follow steps 2 and 3 for the other wire. Gently remove the excess wire.
- c. Repeat this step for each pair of wires.

Step 4 110 Panel

- a. Strip 7.5 cm (3 in) from the other end of the cable and terminate it on the designated row and position of 110-connection block AA or BB-5. This block is located on the relay rack.
- b. Install a C4 clip over the Category 5e cable using the multipair termination tool.

Step 5 RJ45 to 110 Adapter Cable

- a. An RJ-45-to-110 adapter cable is a cable with an RJ-45 connector on one end and a connector that will plug into a 110-panel on the other end.

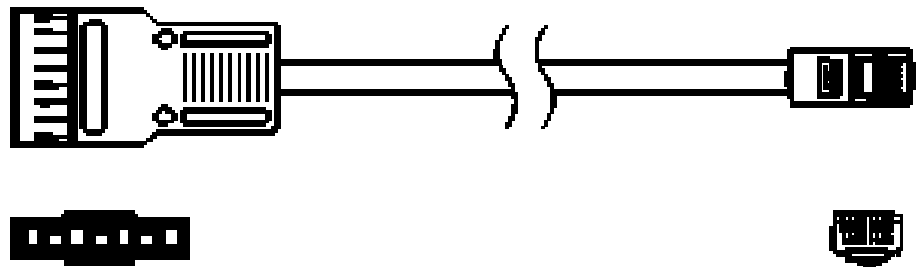

- b. Will this cable test as a straight cable, or a cross over cable?

- c. Explain why.

d. Snap the adapter over the installed C4 clip. Using the Fluke 620 or LinkRunner, test the cable between the patch panel and the 110-connection block.

e. What are the results of the test?

f. Was the initial assumption correct?

Step 6 Clean Up

Ensure that all tools are properly stored. Remove all trash and debris.

Lab 3: Tool Usage and Safety

Objectives

- Identify the tools that are used in cable installations.
- Examine and handle the tools that are used in cable installations.

Background/Preparation

The type of cable that is being installed determines the tools that are needed for a job. Proper tools are required to install cables correctly and safely. While not every tool will be used in every cable installation job, it is important to know about most of the tools and supplies that may be used to ensure quality installations and to complete the jobs in a safe and timely manner.

Safety is a consideration for every task. It is critical that precautions are taken to ensure that the job is done safely. Knowing how to use the tools will help prevent injury to people.

The purpose of this lab is to identify the commonly used tools and supplies that can be used in cable installation jobs and learn how to use them safely. Keep in mind that the names of some tools may vary between regions and countries and installers often use nicknames for some tools. Work in teams of 2 to 4.

Warning: Instructor MUST be present during this lab. Some of the tools introduced in this lab are very dangerous. Before handling each tool, read the section in the lab that corresponds to the tool. The section will review how each tool works and review any safety measures that must be followed.

The following resources will be required:

- Cutting tools
- Terminating tools

URLs

http://www.du.edu/risk/Tool_Safety.html

<http://siri.uvm.edu/ppt/handsafe/handsafety.ppt>

Step 1 Cutting Tools

Handle all of the tools listed. Simulate how they would be used in the field.

Panduit Wire Stripper Tool



The Panduit wire stripper tool is used to remove the outer sheath from Category 5e cable and small coaxial cable. The tool is pulled apart to retract the cutting blade. Cable is inserted into the hole and the installer releases the blade. The tool is spun around the cable one turn. It turns in a clockwise direction for cables with thinner jackets and counter clockwise for cables with thicker jackets. The tool is then spread apart to remove the tool. Do not use the tool to pull the jacket off. By dragging the tool over the exposed wires, they can be cut and damaged. The jacket can now easily be pulled off. Because this is a cutting tool, safety glasses should be worn when using this tool.

Electrician's Scissors

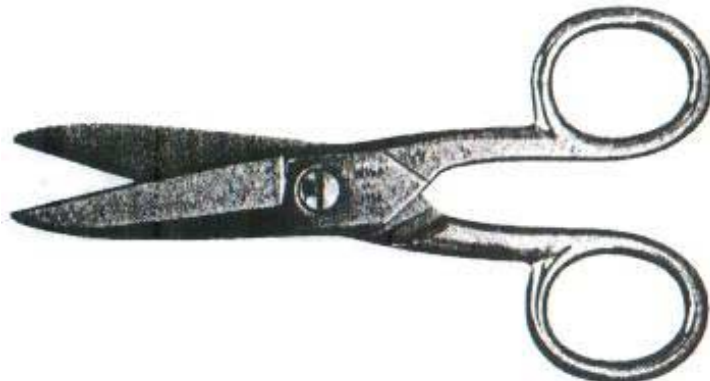

Electrician's scissors, also known as "snips", can be used for cutting Category 5e cable and miscellaneous wire on an installation project. There are two notches on one of the blades. These notches are used to strip insulation from individual conductors. The scissors can also be used for scoring cable jackets. As with other cutting tools, care should be taken not to pinch fingers between the handles or cut fingers. Always wear safety glasses when using snips.

Panduit Wire Snipping tool



- a. The Panduit wire snipper tool is used for cutting excess wire when installing a TX Mini-Jack. The tool will cut copper conductors flush with the termination cap. The wire snipper tool should not be used for cutting Category 5e cables. It is designed for cutting individual cable pairs only. This tool is very sharp and care should be taken when using it. Remember to be careful of the sharp tips on the blades as well. As with all cutting tools, safety glasses should be worn when using this tool.
- b. How many times is the cable-stripping tool rotated to remove a cable jacket?

-
- c. Which cutting tools require safety glasses when using?
-
-

Step 2 Termination Tools

Handle all of the tools listed. Simulate how they would be used in the field.

Panduit Single Pair Punch Tool



The single pair punch tool is used for terminating cable pairs on termination blocks and on the back of patch panels and jacks. The tool will accept blades from all of the popular termination panels. The tool in the lab is equipped for terminating cable pairs on 100-blocks. The blade is reversible. It has a cut position on one side. In this configuration, the tool will punch down a wire and cut off the excess wire in a single motion. The other side of the blade will punch down without cutting. The cutting side is marked on the body of the tool. Blades are removed by twisting the blade counter clockwise and pulling the blade out of the tool. To install the blade, insert it into the tool and twist clockwise. Be careful when using this tool or changing the blades because the small blade on the end can cause cuts.

A wire is inserted into its slot at a termination point. Grasp the tool by the handle. Keeping the tool perpendicular to the block, push the blade into the slot where the wire would be. This is an impact tool. As the handle is pushed, spring tension increases until the tool snaps and releases the energy of the compressed spring. The wire is completely seated into its position and the excess wire is cut off. The tool features an adjustable impact setting.

Panduit Multi-Pair Punch Tool



The multi-pair punch tool is used to insert as many as five pairs of conductors into 110-blocks.

The tool is also used to terminate three, four, or five pairs of conductors at a time by seating “C” clips over them after they have been inserted. The multi-pair punch tool features reversible and replaceable cutting blades. By twisting the head of the tool, a detent is released and the head can be removed from the tool. Cutting blades are slid out from the side of the head. The blades can be installed facing forward for cutting, or facing backward for seating “C” clips. Be very careful with this tool because it has numerous small blades that can cause cuts. The tool is used in a fashion similar to the single pair punch tool. Multiple pairs are inserted in the block, the tool is placed over the pairs, and the installer pushes on the tool until the energy in the spring is released in a sharp impact. This is a high impact tool and is not suitable for use on the back of patch panels.

TX Mini-Jack Termination Tool



a. The TX Mini-Jack termination tool is used to press the termination cap into a TX Mini-Jack. The termination tool assures a proper and uniform installation of the termination cap into the jack.

b. Describe the difference between the two ends of the blade on the 110-punch tool.

c. How is the blade removed on the multi-pair punch tool?

d. How is the blade removed on the 110-punch tool?

e. Why does the multi-pair punch tool have a reversible blade?

f. Why does the 110-punch tool have a reversible blade?

g. What tool is used to terminate a mini-jack?

h. Can the multi-pair punch tool be used at the back of a patch panel? Why or why not?

Step 3 Crimp Tools

Panduit RJ-45 Crimp Tool

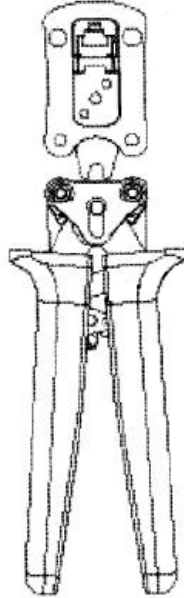

- a. The RJ-45 crimp tool is used for installing RJ-45 plugs on the end of a cable. Wires are inserted into the plug following the proper color code. The plug is inserted into the tool until the plug “clicks” into place. The handles of the tool are squeezed completely until they release. This is a ratcheting tool, so the handles will not return to their full open position until the tool fully closes. Keep fingers out of the open jaws of the tool. There is a release lever between the handles of the tool that will allow the jaws to open without fully closing them. This is a safety feature.

- b. What are the two ways used to open the RJ-45 crimp tool?

Lab 4: Identification of Cables

Objectives

- Identify the different types of cables used in this course.

Background/Preparation

Category is the term used to distinguish the grades of twisted-pair cables. Each grade is distinguished by the number of wires in the cable, the number of twists of the wires, and the speed of data transmission that can be accommodated. This lab will identify several categories of copper cables.

The instructor or lab assistant will prepare 0.3 m (1 foot) - 0.6 m (2 feet) lengths of each type of cable listed below. Strip off 15 cm (6 inches) of the outer sheathing at one end of the cable so that the construction of the cables can be examined.

Notice that there is a minimum and maximum cutting edge on the cable-stripping tool. Use the minimum cutting edge to insure that the conductors are not nicked. Make sure a maximum of two 360-degree turns are used with the cable-stripping tool to prevent nicking the conductors. Work in teams of 4 to 5 people. The following resources will be required:

- Category 5e UTP stranded-conductor cable
- Category 5e UTP solid-conductor cable
- Category 6 UTP stranded-conductor cable
- Category 6 UTP solid-conductor cable
- Cable stripping tool
- Tape measure

URL

<http://www.panduit.com>

Step 1 Examining Category 5e UTP solid-conductor cable

- a. Select the Category 5e UTP solid-conductor cable by inspecting the cable jacket. It identifies the type of cable.
- b. What is the marking on this cable?

- c. Examine the inside structure of the cable.
- d. How many pairs are in the cable?

- e. What is used to help identify a particular wire?

- f. Examine the individual wires.
- g. How many strands of copper are within each wire?

Step 2 Examining Category 5e UTP stranded-conductor cable

- a. Select the Category 5e UTP stranded-core cable.
- b. Does the outer jacket differ from that of the Category 5e UTP solid-conductor cable?

- c. What is the marking on this cable?

- d. Examine the internal construction of the cable.
- e. How does it differ from the Category 5e UTP solid-conductor cable?

- f. How many strands of copper are within each wire?

Step 3 Examining Category 6 solid-conductor cable

- a. Select the Category 6 UTP solid-core cable. Inspect the cable carefully, and note that the cable's jacket identifies the type of cable.
- b. What is the marking on this cable? _____
- c. Examine the internal construction of the cable.
- d. How does it differ from a Category 5e UTP cable? _____
- e. How many strands of copper are within each wire? _____

Step 4 Examining Category 6 UTP stranded-conductor cable

- a. Select the Category 6 UTP stranded-conductor cable.
- b. What is the marking on this cable? _____
- c. Examine the internal construction of the cable.
- d. How many pairs are in the cable? _____
- e. How does it differ from a Category 5e UTP cable? _____
- f. How many strands of copper are within each wire? _____

Step 5 Answer the following questions

- a. Describe the differences between solid and stranded core cables.

- b. Describe the differences between Category 5e and Category 6 cables.

Lab 5: Category 5e Jack Termination

Objectives

- Practice proper safety procedures when using cabling tools.
- Use the T568B standard when terminating Category 5e cable on a modular jack at the modular patch panel.

Background/Preparation

Jacks terminate the Category 5e cable. Modular jacks can be inserted into modular patch panels to allow the termination of the cable with the same Mini-Jack module used in a wall outlet.

To provide connectivity in the structured cable system infrastructure, the installer must be able to terminate Category 5e cable with jacks.

During this lab, each student on the team will terminate one end of a Category 5e cable with an RJ-45 Mini-Jack jack and insert it into a patch panel. Work in teams of 2 people. The following resources will be required:

- 2 RJ-45 Mini-Jack jack
- 60 cm (2 feet) of Category 5e UTP solid-core cable
- Safety glasses
- Wire stripper tool
- Mini-Jack module termination tool
- Permanent marker pen
- Wire snipping tool
- Electrician's scissors
- Fluke 620 cable meter or LinkRunner

URL

<http://www.panduit.com>

Safety

Make sure to wear safety glasses or goggles during the entire lab.

Step 1 Label the Cable

Place a label on the cable approximately 15 cm (6 inches) from the end. Each cable must have a unique identifier. For this exercise, each student should use a permanent marking pen to write their first name on the end of the cable that they terminate. The name should be followed by pp1, for patch panel 1, and the port number of the patch panel to which the student will insert the jack.

Step 2 Remove the Sheathing

Now that the cable is the proper length and has a unique label, remove the sheathing without causing any damage to the conductors. Use the copper strip tool to ring the cable about 5 cm (2 inches) from the end of the cable. Should there be any exposed copper on the conductors where the cable jacket was removed, cut off the end of the cable and remove 5 cm (2 inches) of jacket again. If needed, repeat the labeling process.

Step 3 Prepare the Cable and Jack

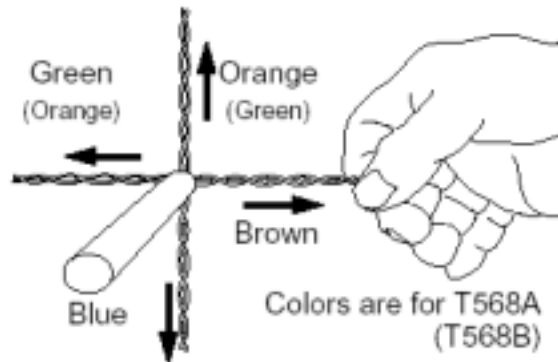

- Separate the twisted pairs from each other without untwisting the pairs. Pull the wires pairs to set their positions. Use the T568B wiring standard when terminating this jack.

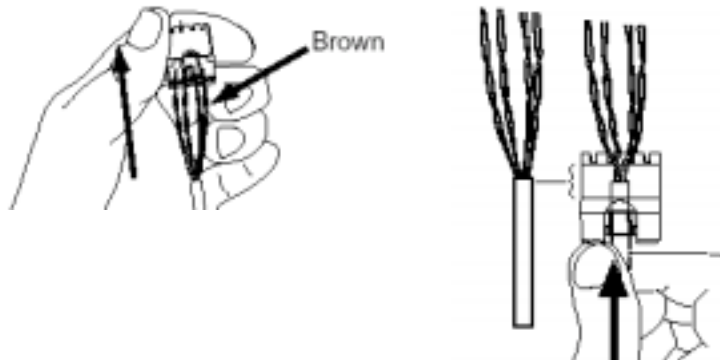

- Gather the twisted pairs and insert them into the cap.

Push the cable jacket until the jacket end is located under the label.

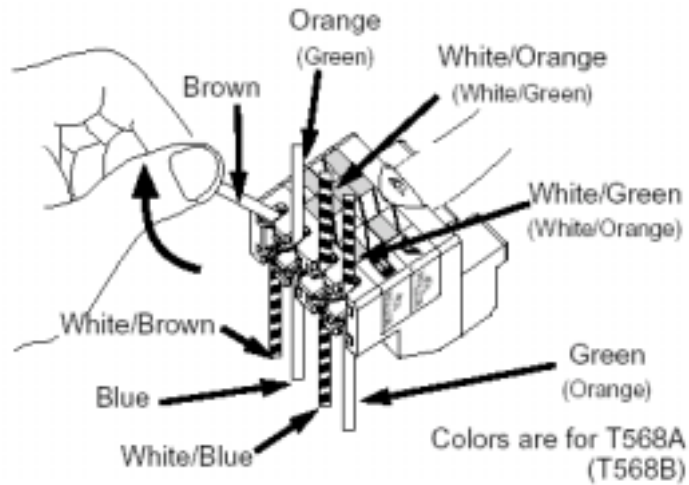

- c. Untwist the pairs, one at a time starting with the outside pairs, and place them into the correct slots. It is very important to untwist each pair only as far as required to place the conductors in the correct slots.

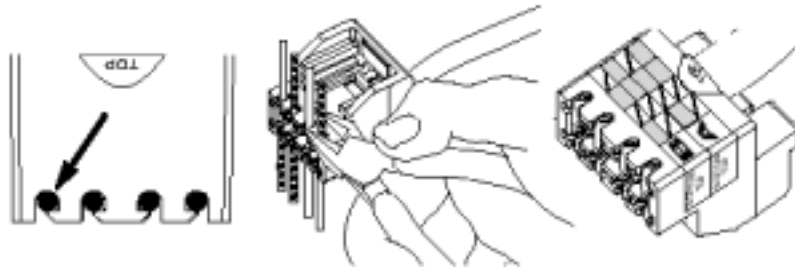

- d. Trim each conductor flush with the cap with the wire snipping tool. Be sure that all of the conductors are still seated in their slots.

Step 4 Terminate the Cable

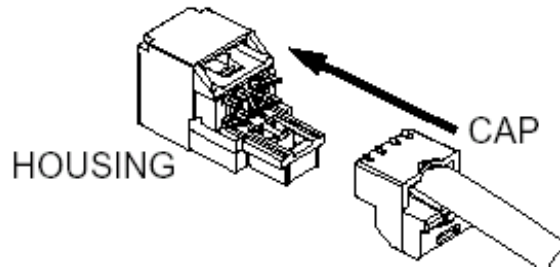

- a. Slide the front of the Mini-Jack into the backing, making sure that it is straight.

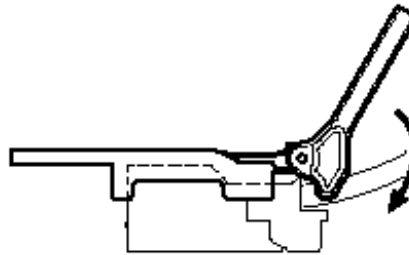

- b. Use the Mini-Jack tool to press the two pieces together until they snap. The cable has now been terminated. From behind the panel, snap the jack module into a vacant position on the modular patch panel.

Step 6 Terminate the Other End of the Cable

Install the other Mini-Jack module by using the T568B wiring standard to terminate the cable and insert this jack into the correct patch panel port.

Step 7 Testing

- a. Use the Fluke 620 cable meter or LinkRunner to test the jack installation.
- b. What are the results of the test?

- c. Are the results exactly the same when the second jack is tested?

- d. Why or why not?

Step 8 Clean Up

Ensure that all tools are properly stored and remove all trash and debris from the work area.

Lab 6: Category 6 Jack Termination

Objectives

- Practice proper safety procedures when using cabling tools.
- Terminate a Category 6 cable using proper techniques for high-bandwidth data cabling.

Background/Preparation

Certain precautions must be followed when jacks terminate Category 6 cable. The tolerances of dimensions increase in importance as the frequencies of voltages on the cables get higher and the data rates increases.

The following instructions explain how to terminate Panduit MINI-COM TX-6 PLUS Modules. Although installation techniques will vary slightly, attention to these procedures will help students gain facility with many Category 6 terminations and devices.

During this lab, each student on the team will terminate one end of a Category 6 cable with an RJ-45 Mini-Jack jack and insert it into a patch panel. Work in teams of 2 people. The following resources will be required:

- 2 RJ-45 MINI-COM TX-6 PLUS Modules
- 60 cm (2 feet) of Category 6 UTP solid-core cable
- Safety glasses
- Wire stripper tool
- Permanent marker pen
- Mini-Jack module termination tool
- Wire snipping tool
- Electrician's scissors
- Cable tester for verifying that the wires were connected correctly

URL

<http://www.panduit.com>

Safety

Make sure to wear safety glasses or goggles during the entire lab.

Step 1 Label the Cable

Place a label on the cable approximately 15 cm (6 inches) from the end. Each cable must have a unique identifier. For this exercise, each student should use a permanent marking pen to write their first name on the end of the cable that they terminate. If the jack is to be inserted into a patch panel, the name should be followed by pp1, for patch panel 1, and the port number of the patch panel to which the student will insert the jack.

Step 2 Remove the Sheathing and Order the Pairs

Now that the cable is the proper length and has a unique label, remove the sheathing without causing any damage to the conductors. Use the copper strip tool to ring the cable about 5 cm (2 inches) from the end of the cable. Should there be any exposed copper on the conductors where the cable jacket was removed, cut off the end of the cable and remove 5 cm (2 inches) of jacket again. If needed, repeat the labeling process.

Avoid damaging or disturbing the cable pairs any more than is necessary. Fan out the cable pairs as shown in Figure 1, ordering the colors as shown in Figure 2. Trim the pairs to length as shown in Figure 1. Note that these instructions apply to solid, not stranded, conductors.

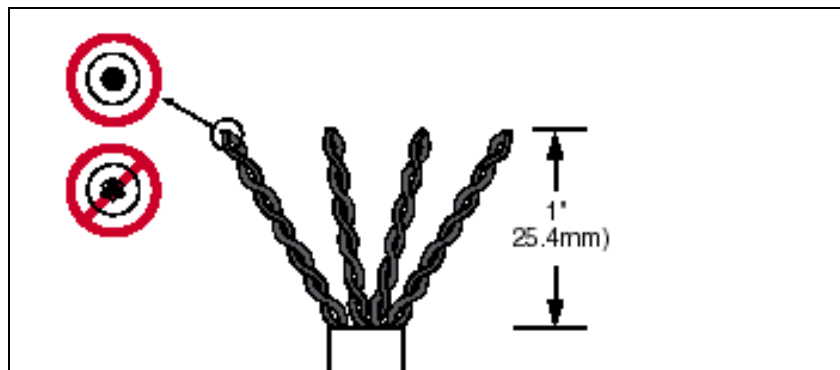

Figure 1

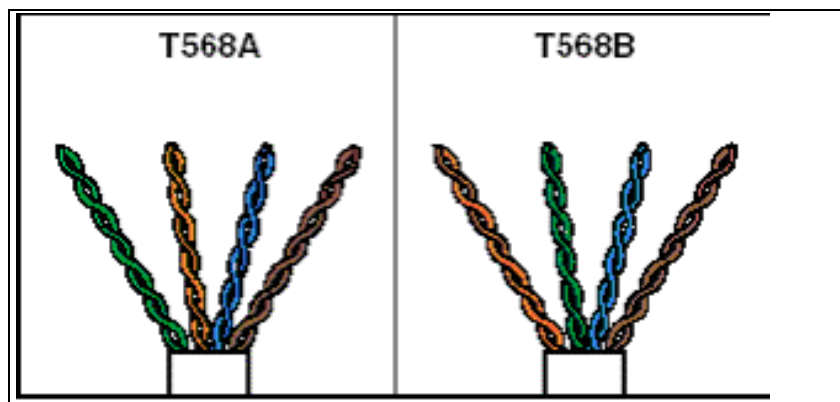

Figure 2

Step 3 Insert the Cable into the Jack

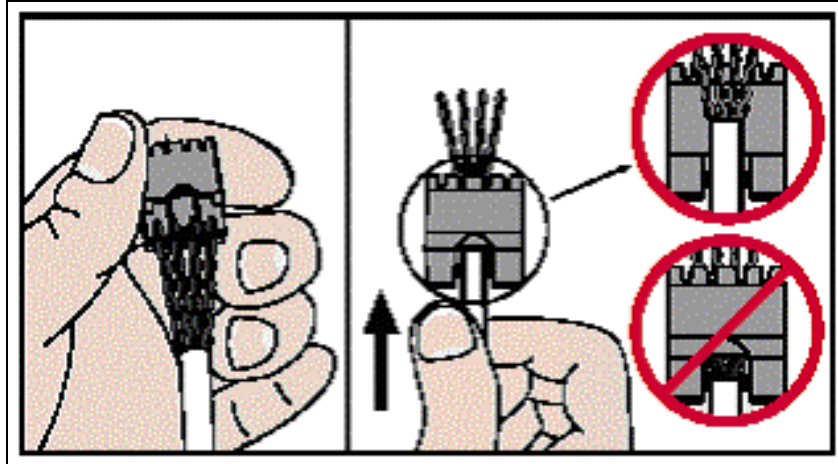

Figure 3

Holding the module assembly with the correct side up as shown in Figure 3, and with the wire pairs oriented as shown in Figure 2, gently push the ordered pairs through the holes in the module assembly. Insert the cable fully, making sure that the pairs go through the correct holes.

Step 4 Insert the Wires into the Notches

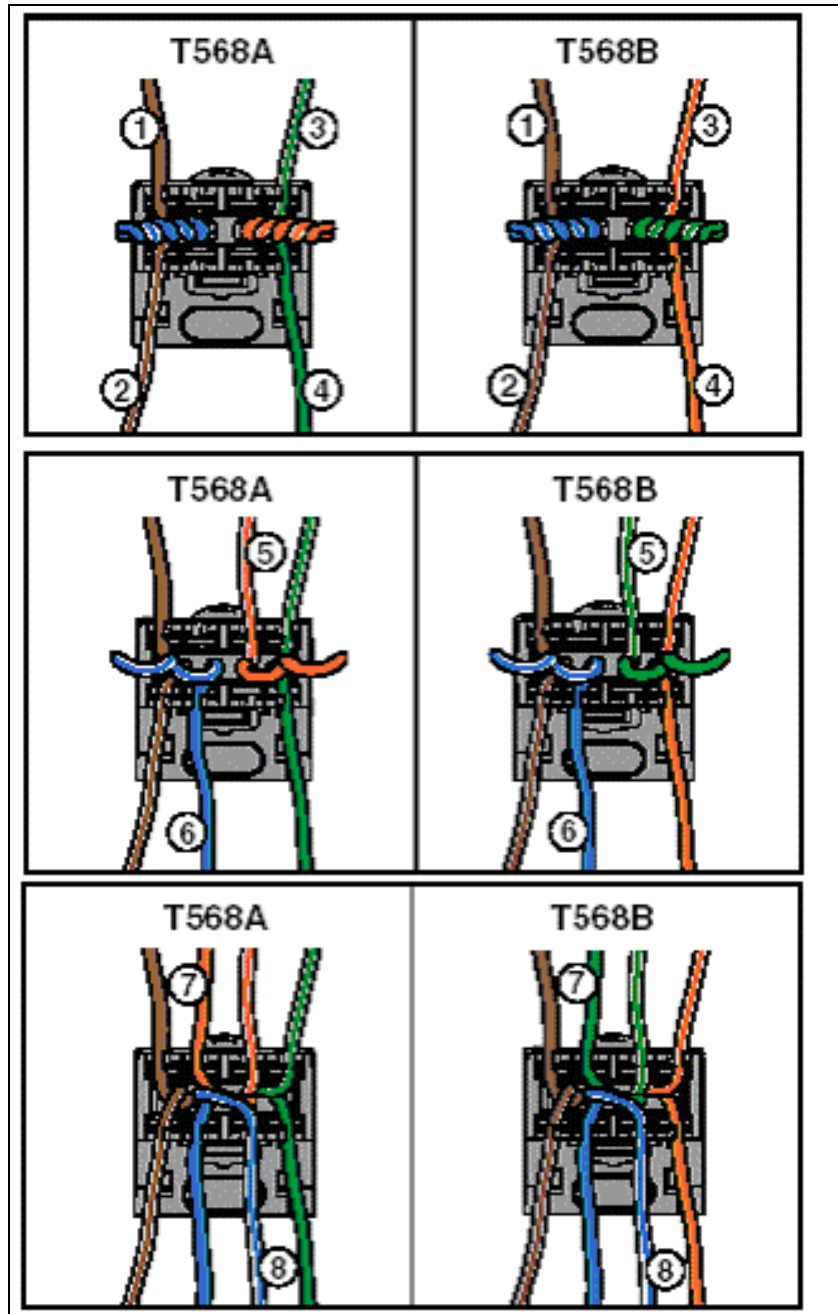

Figure 4

Use Figure 4 as a guide to twist the pairs in the order shown. One at a time starting with the outside pairs, place the wires into the correct slots. It is very important to untwist each pair only as far as required to place the conductors in the correct slots.

Step 5 Snip the Wire Ends Flush

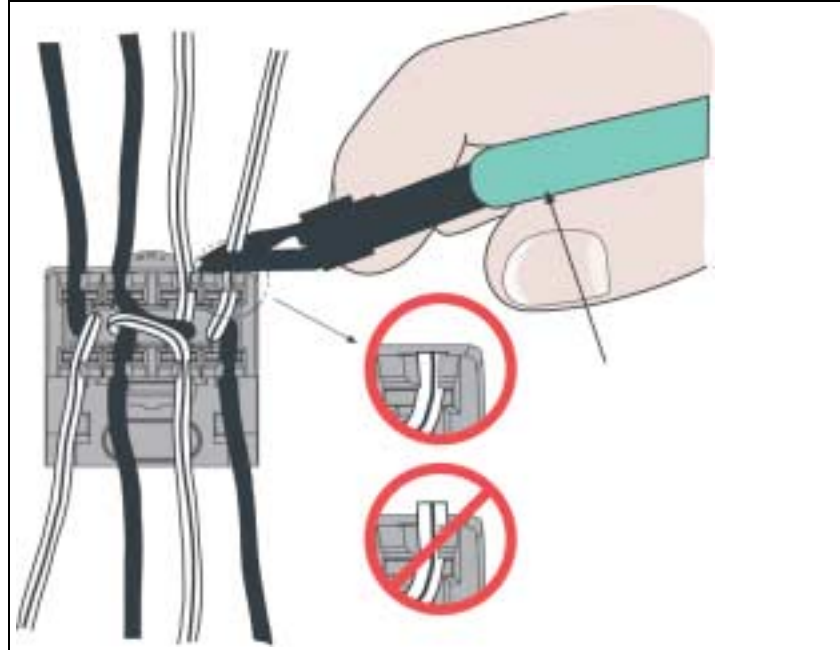

Figure 5

Trim each conductor flush with the cap with the wire snipping tool. Be sure that all of the conductors are still seated in their slots as shown in Figure 5.

Step 6 Assemble the Module

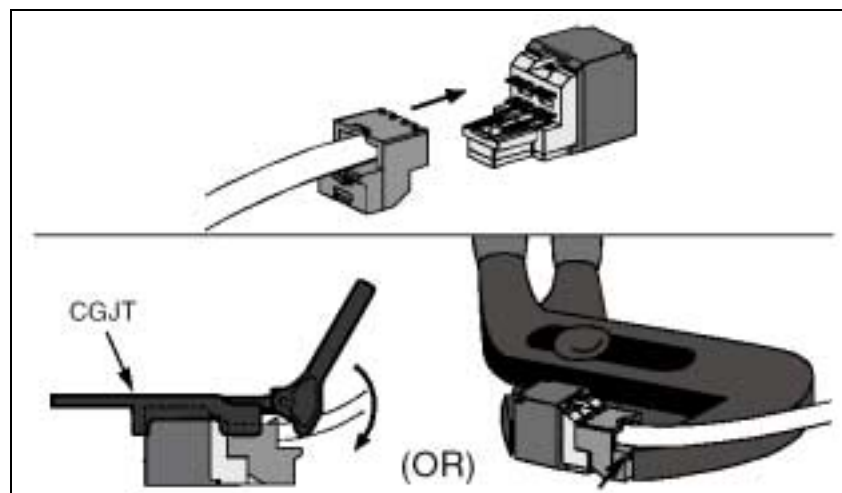

Figure 6

- Slide the front of the Mini-Jack into the backing, making sure that it is straight as shown in the top image of Figure 6.
- Use the Mini-Jack tool to press the two pieces together until they snap as shown in the bottom image of Figure 6. The cable has

now been terminated. Alternatively, use slip-jaw pliers with the jaws set to the distance of the finished jack. If the pliers consistently damage the modules, try wrapping a little electrical tape over each jaw before using.

Step 7 Shielded Cable Installation

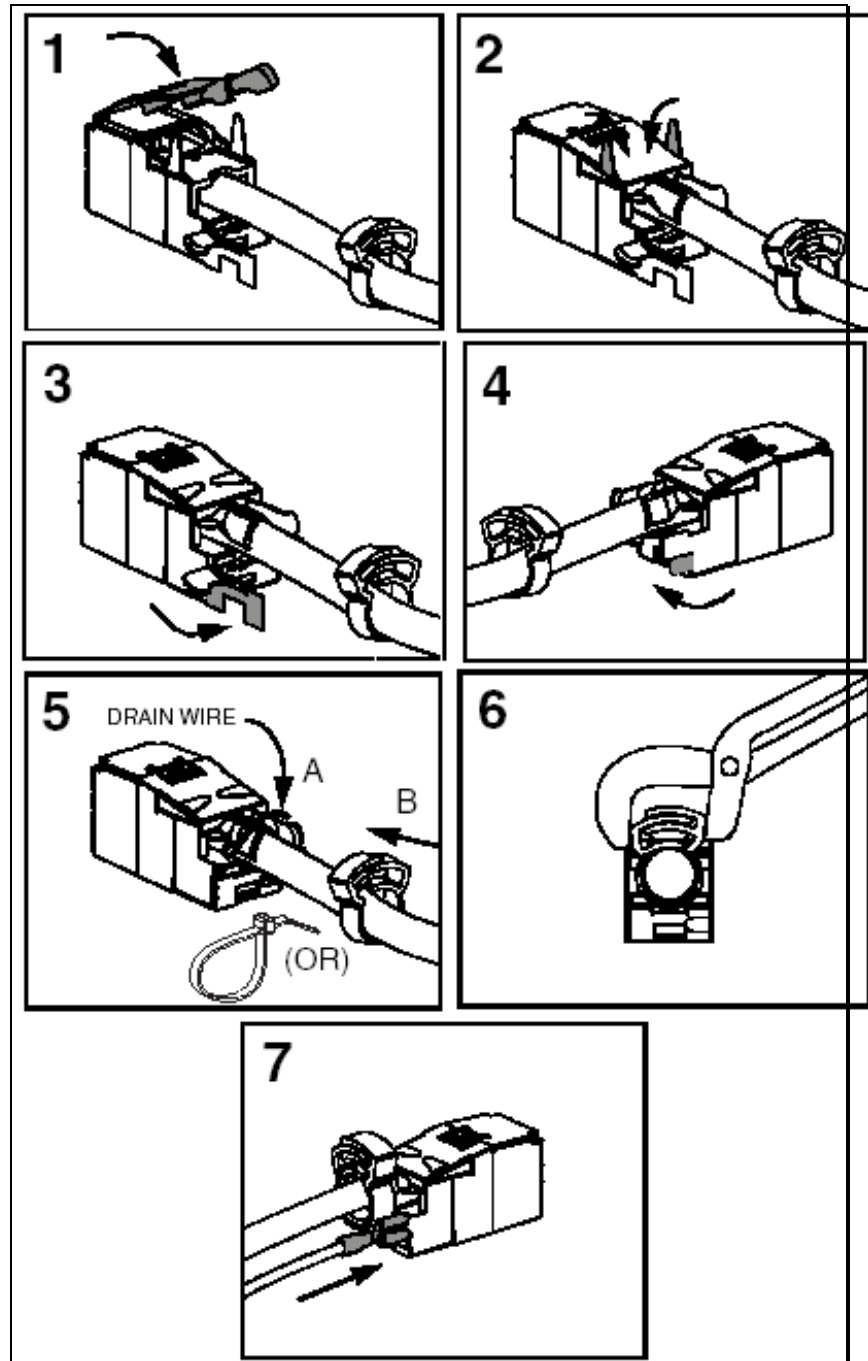

Figure 7

For shielded cables, it will be necessary to follow steps 1 through 7 in Figure 7 to install the metallic cover.

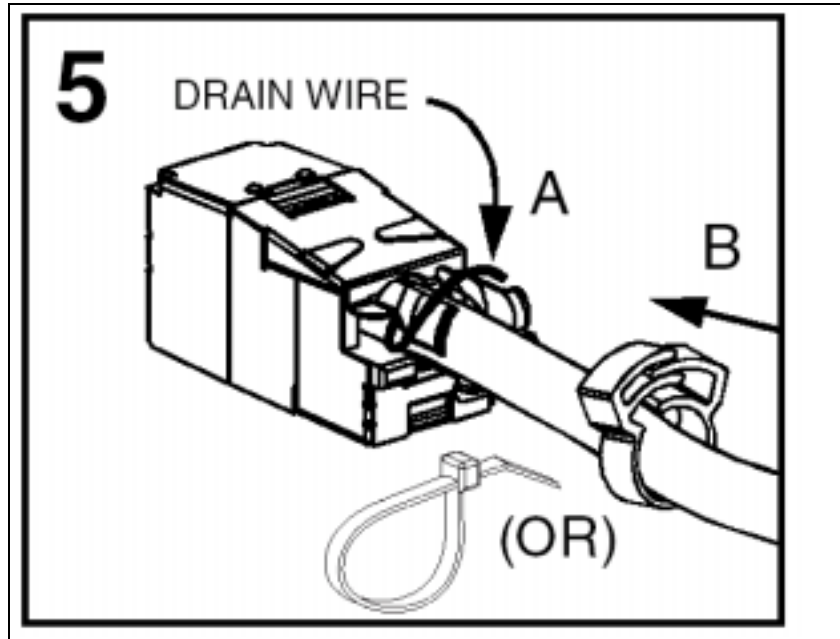

Figure 8

Figure 8 is a close-up of step 5 in Figure 7. In this step, route the drain wire to the rear of the module and wrap it over the ground lug that extends to the rear of the cover. Secure the drain wire with the plastic crimp ring as shown. If the module is to be used in a surface mount fixture, a nylon cable tie should be used instead.

Step 8 Terminate the Other End of the Cable

Install the other Mini-Jack module by using the same wiring pattern, T568A or T568B, to terminate the cable.

Step 9 Testing

Use the cable tester test the jack installation.

- a. What are the results of the test?

- b. Are the results exactly the same when the second jack is tested?

- c. Why or why not?

Step 8 Clean Up

Ensure that all tools are properly stored and remove all trash and debris from the work area.

Lab 7: Terminating Category 5e to a 110-Block

Objectives

- Terminate Category 5e cable to a 110-type termination block.
- Properly use a 110 punch-down tool and 110-multipunch tool.

Background/Preparation

The installer must be able to properly punch-down a 110-block. It is important that each punch-down is executed correctly to ensure proper connectivity.

A 110-block is a device used to terminate wires in a common place. Wires from internal data networks and telephones are collected in the block. Wires from outside the building are collected in a separate block. These two blocks provide a way to connect the two collections of wires in order to supply connectivity from external sources to the desktop. This system of wire management keeps the wires organized and allows for quick changes.

The instructor or lab assistant will designate the location of the punch-down indicating the row 1-4 and position 1-6 on the block. Work in teams of 1 to 4 people. The following resources will be required:

- 110-punch block
- 1 m (3 feet) of Category 5e UTP cable
- C-4 Clips
- Copper strip tool
- Impact tool with 110 cutting blade
- 110-multipunch tool
- Pliers

URL

<http://www.panduit.com>

Safety

Safety glasses should be worn when using cutting tools. Use caution when using impact tools because they have sharp blades.

Step 1 Cable Preparation

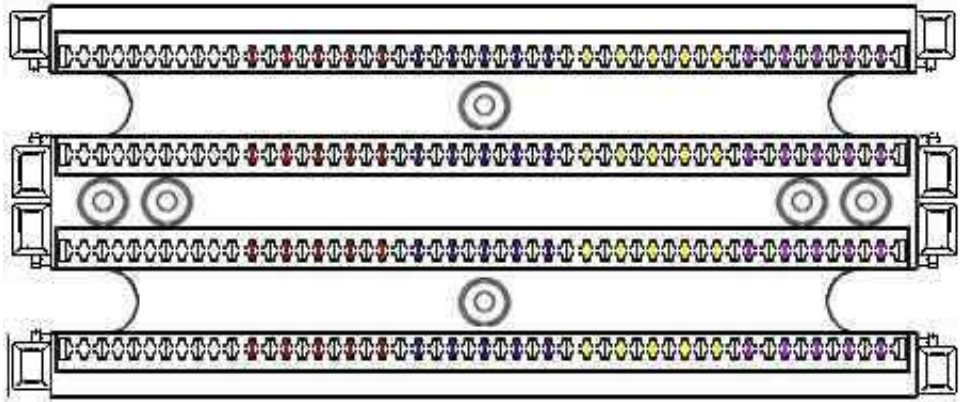

- a. Determine the position on the 110-block that will be used to terminate the cable. Since a four-pair cable is being used, positions are determined by counting four pairs from the left end of the block. For example, position 1 would be the first four pairs, position 2 would be the second four pairs, and so on. Label the cable with respect to its position on the block. If the plan is to terminate the cable on position 3, use the labeler and pen to number the cable “#3”.
- b. Now that the cable has a unique label, remove about 5 cm (2 inches) of sheathing without causing any damage to the conductors.

Step 2 Fan the Conductors

- a. Separate and fan out the conductor pairs without untwisting the wires.
- b. Place the wires one pair at a time into the termination points 7-10 cm (2-3 inches) from the end of the wires. This will place the two wires in the correct position to be punched down while ensuring that the twisting continues up to the point of termination. Use the proper color-coding scheme, which is white/blue, white/orange, white/green, and white/brown. Make sure that the tip colored wire is placed to the left and the ring to the right.

Step 3 Punch Down

- a. Place the single wire punch down tool over the wire that will be punched. Be sure that the blade will only cut off the end of the wire. The cutting edge of the blade should be facing the direction to be cut.

- b. Press firmly on the impact tool until it clicks. This will ensure that the wire has been punched down all the way and that the excess wire has been cut. Do not hit the tool to punch down the wires.
- c. Repeat this step for the other wire. Gently remove the excess wire.

Step 4 Punch Down the Rest of the Pairs

Repeat steps 2 and 3 for each pair of wires.

Step 5 The C-4 Connector



- a. A C-4 connector is used for four-pair cables. The C-4 connector is used to make the actual connection to the Category 5e cable. Place the C-4 connector over the wires punched down, being sure to match the color-coding correctly.
- b. Position the 110-multipunch tool over the C-4 connector. The multipunch tool is used to seat the C-4 connector.
- c. Press firmly on the multipunch tool until it clicks. This will ensure that the C-4 connector has been attached correctly and the wire has been properly terminated.

Step 6 Inspection

- a. Look carefully at the punched down cable.
- b. Approximate the length of the wires that are untwisted?

- c. What is the maximum allowable untwist length? _____
- d. How much of the pairs are exposed? _____
- e. How many Category 5e cables can be terminated in a single row of a 110-block? _____

Step 7 Clean Up

Remove the C-4 connector that was installed by using a pair of pliers to grasp the clip and pulling it straight back until it pops off. Make sure all tools are properly stored and that all trash and debris has been removed from the work area.