



# Business Process Modeling



## Quick Start Guide



Business  
Process  
Modeling  
Readiness  
Guide

# GET STARTED

## READY — UNDERSTAND WHY BUSINESS PROCESS MODELING IS A GOOD THING



Documenting business processes is valuable! It provides a path to process and program improvements, increases efficiency in day to day operations, educates staff and advances understanding of the business, which allows your team members to better serve the people of the State of California.

Business Process Modeling (BPM) is a methodology used to identify and document a visual illustration of your organization's current business processes.

Many organizations either have little to no documentation or the documentation is in large outdated manuals. BPM is done as part of good business, not just because a new project or system re-design is on the horizon. This guide helps organizations and their workforce prepare for process re-engineering by defining the basic steps of BPM.

## SET — DETERMINE YOUR LEVEL OF PARTICIPATION IN BPM



It's important to define your level of participation and understand what role you will undertake. Roles determine what type of tasks each person will be responsible for. When each person knows their role, BPM is a positive experience. In other words, know why you are part of BPM and understand your role. This information provides you with clear direction of what is expected of you, what your tasks are, and how to complete them.



It's also important to understand the roles and interests of others. You will be working closely with your fellow team members. Each role is an important part of conducting an effective and successful BPM.

Are you the...

Roles	Definitions	Page
Executive / Management	Sponsors the effort, promotes the benefits and provides appropriate resources to ensure success.	2
Project Manager - Project Management Office (PMO)	Plans, organizes, motivates and controls resources to achieve project goals.	3
Process Documenter (Modeler)	Creates the documented business process modeling artifacts.	4
Business Process Subject Matter Expert (SME)	Is the expert on business processes, responsible to convey this information to the Process Documenter.	5

## GO! — BEGIN YOUR BPM JOURNEY



The culture of your organization is important because BPM efforts result in significant changes. How well and how quickly a change can be absorbed and what the benefits of the change are; heavily depend on the culture. There are three personality types that have very different general attributes. Keep this in mind as you begin this journey:

- **Cultural Conservatives** tend to make decisions along a path determined by the management structure; they typically take no action until they are in pain
- **Cultural Moderates** operate in a more stable, but sometimes disjointed fashion; they tend to seek parity with other enterprises
- **Cultural Aggressors** make decisions with a high degree of coordination; they are committed to seizing the advantage



Use this Quick Start Guide to begin your journey into BPM. Locate your role in the following pages. Review each step, follow the process, ask questions, and maintain communication with fellow BPM participants. You will learn how to implement a repeatable process to conduct analysis of As-Is (current or existing) business processes.

# Role: Executive / Management

## WHY SUPPORT BPM?

Executive sponsorship is the single most important element required for successful BPM governance. A vital aspect of effective BPM is your involvement and participation. Your ongoing commitment and willingness to devote the necessary resources and time are crucial to the success of the BPM efforts.

Benefits are:

- Improves organizational agility
- Bridges the gap between business and IT; improves communication
- Assists business teams to gain full understanding of their processes; not what they think is happening or what should happen, but what is *really* happening
- Promotes process refinement
- Helps the business recognize where change should occur; in the system or in the business process

## WHAT IS YOUR ROLE?

page 11 in the BPM Guide

- You are the visionary leader; use your transformational skills and influence to drive change in your organization
- Provide relevant resources for the modeling activities
- Select a Project Manager (PM) who will be responsible to ensure your BPM goals are accomplished
- Empower your chosen PM to be the BPM champion and drive the development of BPM
- Be aware and promote the benefits that can be obtained through BPM
- Participate in the decision making activities to resolve conflict and achieve goals
- Support and participate in the overall business process modeling activities



## WHERE DO YOU BEGIN?

page 9 in the BPM Guide

Understand your organization's level of BPM maturity and what needs to be done to increase BPM maturity. The BPM Maturity Model below depicts the six phases of BPM maturity. Most organizations are in the early stages. The PM is responsible for moving your organization through the phases of maturity. Select a PM as the first step. Set goals and schedule follow up meetings to stay informed and up-to-date.

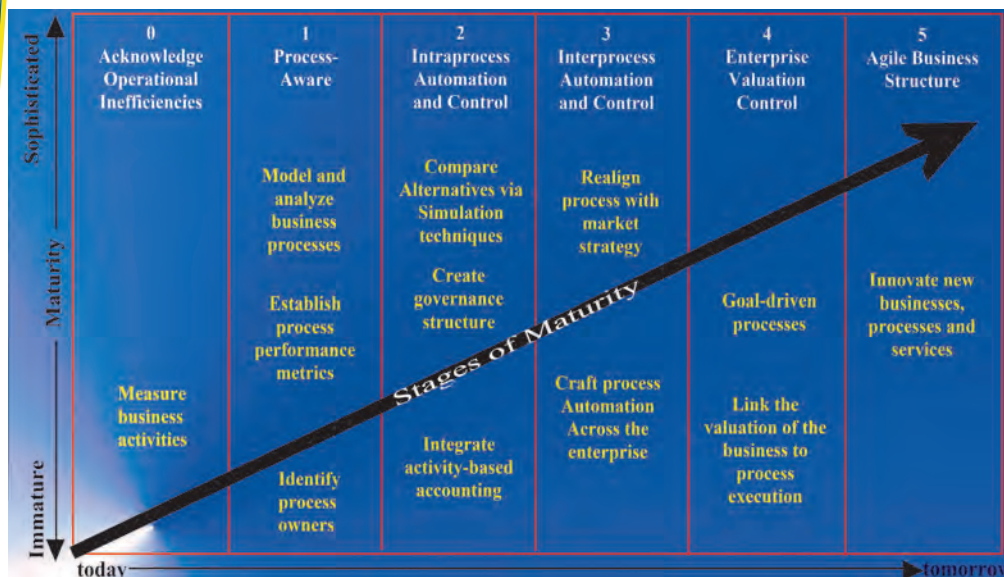

## BPM Guide

### Key

### Chapters

- ⇒ 2: BPM - Planning
- ⇒ 3: Assessing Readiness for BPM
- ⇒ 7: Potential Pitfalls When Working on BPM
- ⇒ 8: Escalation and Decision Making Process

## Tips and Tricks

### HOW TO KNOW YOU ARE GETTING RESULTS?

- Your leadership team is reporting improvements and a more streamlined approach in their business processes
- Customer satisfaction has increased and response time has decreased
- Strategic Goals are being met
- Staff really are getting more done with less
- Your organization has the time to address and resolve long standing issues
- Other leaders are asking for your secret to BPM success

# Role: Project Manager / PMO

## BPM PLANNING *page 2 in the BPM Guide*

Applying project management best practices will help you deliver well documented business processes to meet your Executive's expectations. Project management is the discipline of planning, organizing, motivating and controlling resources to achieve specific goals.

The primary challenge of project management is to achieve all of the project goals and objectives while honoring the project constraints.

The primary constraints are scope, time, quality and budget. The secondary, and more ambitious challenge is to optimize the allocation of necessary inputs and integrate them to meet pre-defined objectives.



## WHAT IS YOUR ROLE? *page 11 in the BPM Guide*

The Project Manager plays a vital role as a leader/champion and is responsible to ensure all BPM activities are completed and goals are achieved.



Specific responsibilities include:



- Define the scope of the project. Decide what business process to model and to what level of detail
- Clearly define the BPM purpose and objectives
- Manage your time, apply proper scheduling techniques and adhere to the timeline
- Share information amongst all team members effectively
- Manage quality by outlining exit strategies and formal processes to review the models and information received to develop the models

Don't Forget!

**Executive Communication:** Keep communication channels open and inform project stakeholders on the status; what is going well and what the challenges are.

## BPM Guide

### Key

### Chapters

- ⇒ 2: Planning for BPM
- ⇒ 3: Assessing an Organization's Readiness for BPM
- ⇒ 4: BPM Basics
- ⇒ 5: As-Is Process Modeling Step By Step
- ⇒ 7: Potential Pitfalls When Working on BPM
- ⇒ 8: Escalation and Decision Making Process

### Pitfalls

*page 37 in the BPM Guide*

### BE AWARE OF POTENTIAL ISSUES

- Lack of Organizational Support and Governance
- Lack of Qualified Modelers
- Lack of Qualified Subject Matter Experts (SME)
- SME Disagreement
- Lack of User Acceptance of How the Process is Mapped
- Too Much Detail
- Faulty Swim Lane Usage
- BPM Not Linked to Critical Business Need or Issue Hidden Processes

# Role: Process Documenter (Modeler)

**TAG, YOU'RE IT!** pages 11 and 29 in the BPM Guide

You have been chosen as the Process Documenter, in other words, the Modeler. Now What? First, take some time to read through the BPM Guide. You must familiarize yourself with BPM Basics. There are various methods used to model a business process, and models developed with different methodologies can look very different. It is recommended that an organization pick one methodology and apply it to all process modeling. Work with your Project Manager very closely to adhere to this recommendation.

Successful BPM captures the noteworthy events, inputs, resources, and outputs associated with a given business process. Include the following:

- Goal of the process
- Specific inputs and outputs
- Resources consumed
- Activities and the order in which they are performed
- Significant events that drive or affect the process

## WHAT IS YOUR ROLE?

page 11 in the BPM Guide

- You are the facilitator and writer
- Have a clear understanding of BPM purpose and benefits
- Document the process as the discussion occurs
- Have or obtain knowledge of As-Is business processes
- Have or obtain knowledge on the utilization of modeler tools
- Use your interpersonal skills to get the team to talk and share their knowledge and experience
- Be an active participant in the BPM meetings
- Be flexible; be innovative; think out of the box!
- Gain consensus amongst the team
- Support and participate in the overall business process modeling activities



## How To Document A Process

page 34 in the BPM Guide

A process consists of input, outputs and activities that produces significant outcomes.

One of the tasks in documenting a process is to identify and interview all individuals or groups involved in the process. Each person has significant input to the process.

Document a process by completing these steps:

1. Create a process map.
2. Break down the big picture into sub-processes.
3. Capture each activity or task.

### Helpful Tips:

- Prioritize the processes to be documented
- Start with a simple process versus a complex process
- Identify the key players

## BPM Guide

### Key

### Chapters

- ⇒ 4: Business Process Modeling Basics
- ⇒ 5: As-Is Process Modeling Step By Step
- ⇒ 6: Business Process Modeling Templates
- ⇒ 7: Potential Pitfalls When Working on BPM



## Tips and Tricks

### BPM TEMPLATES

- *Business Area Process Templates help you capture the procedures that govern how a department's business works from an operational level*
- *BPM Templates are used to document your department's process flow, related to the information in the Business Area Process Template*



# Role: Business Process Subject Matter Expert (SME)

## KEY TO SUCCESS

As the Business Process SME, you hold the key to success to achieve accurate and effective BPM results. You are the person in the room with years of experience and knowledge. You have rolled up your sleeves and done the work through the years. It is vital to unlock and document your knowledge during the BPM process.



Benefits you will see to BPM are:

- Bridge the gap between other business team members and improve communication amongst your peers
- Learn and gain a full understanding of all business processes; not what you think is happening or what should happen, but what is *really* happening
- Experiencing process improvement in day to day activities
- Improved relationships during and after BPM
- A chance for your voice to be heard

**WHAT IS YOUR ROLE?** *page 12 in the BPM Guide*



## You're the Expert!

- Most proficient and skilled business/program participant
  - Have the most in-depth knowledge of As-Is (current) business processes
  - Know the facts in a particular program or area of the business
  - Share your knowledge and experience
  - Be an active participant in the BPM meetings
  - Be responsible for accuracy
  - Bring real world business process examples
  - Remember user needs
- Support and participate in the overall business process modeling activities
  - Review the BPM Guide to dive deeper into how the Process Documenter will document the business processes; visual depictions of business processes are easy to understand. Remember: A picture is worth 1000 words...

**WHERE DO YOU BEGIN?** *page 29 in the BPM Guide*

Start thinking about your business processes, pull out current documentation (if available) and meet with your Project Manager and Process Documenter. As you work together, you will soon find your processes will turn into well diagrammed visual documents as shown below in this example.

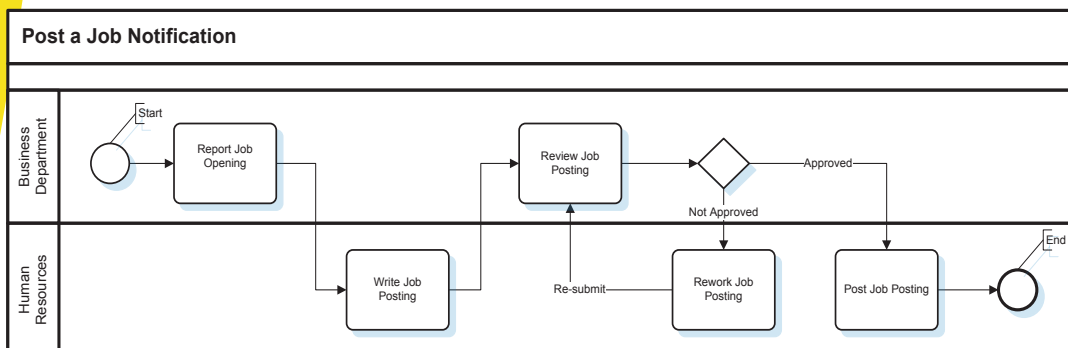

## BPM Guide

### Key

### Chapters

- ⇒ 3: Assessing an Organization's Readiness for BPM
- ⇒ 4: BPM Basics



## ROLE OVERLAP

Develop strong relationships and work closely with the Process Documenter and Project Manager

You will find the roles will overlap in some areas.

# Six Steps to Model As-Is Processes

Page 29 in the BPM Guide

A Business Process Model is a diagram representing a sequence of activities. It depicts events, actions and links or connection points. These steps are your guide for how to begin. Follow the six steps below to business process improvement through BPM.

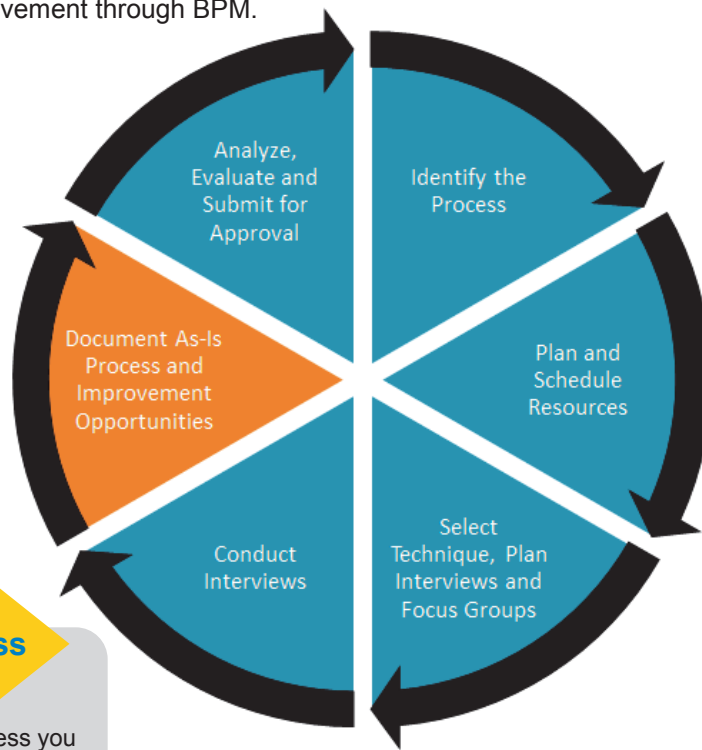

## 1 Identify the Process

Identify the business process you want to model.

## 2 Plan and Schedule Resources

page 29 in the BPM Guide

**Plan - Who and what systems are involved in the process?**

- Use roles rather than job titles to help shift emphasis from a functional to process mindset
- System names should be what the staff and customers in the organization use and call them

**Schedule - Who is involved in the process and what role will they play?**

- Develop a list of tasks, people responsible and time required

## 3 Select Technique, Plan Interviews & Focus Groups

Select a Modeling Technique

pages 29-30 in the BPM Guide

**Plan Interviews and Focus Groups:**

- Prepare for process interviews – individual and/or focus groups
- Review any existing process documentation/models; documentation can help you identify the process experts
- Keep in mind: actual processes most likely have no resemblance to documentation or Standard Operating Procedures (SOP)
- Start with a group interview for an overall picture of interactions between roles, users and systems
- Follow up with individual interviews to get more detail

## BPM Guide Key Chapter

⇒ 4: BPM Basics

### PRIMARY ROLE LEGEND

Project Manager

Process Documenter

# 4

## Conduct Interviews

page 30 in the BPM Guide

Conduct individual interviews in the order the roles appear on the process model.

Know the following:

- Roles from whom the person receives input and gives output
- Input tasks & output tasks (when does the person first become involved and when are they finished?)
- Tasks performed (including decisions in sequence)
- Touch points to other processes

Keep in mind:

- Avoid jargon - the process model must be able to communicate to people in other functional areas
- Display the model as it emerges from the discussion with groups you can use flip charts, a white board, post-it notes or other similar techniques
- Model the official way - if there are enough differences, then people need to see the official way so they can see what deficiencies are causing people to vary from the process

# 5

## Document As-Is Process and Improvement Opportunities

page 29 in the BPM Guide

Consider the following:

- What major activities occur in this process?
- Where do decisions need to be made, or approvals occur before the next step?
- What causes extra work or rework in this process?
- Are there places where more than one method is occurring?
- What factors inhibit process members from performing well?

List each step on its own. Choose a process capturing technique (e.g., sticky note, flip chart, whiteboard diagram, etc.) and work down vertically.

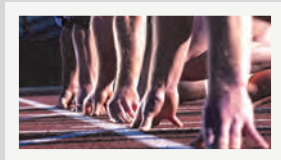

As-Is sequencing & responsibility:

- Arrange the steps in the order in which they occur
- Place each step under the primary role responsible for accomplishing it
- Rearrange steps and players as needed, until they accurately show how the process flows

Classify process parameters:

- Classify Inputs into the following categories:
- **N** = Noise Factors – Uncontrollable factors in the process
- **C** = Controllable Factors – Process factors that can be changed to see the effect on product characteristics
- **S** = Standard Operating Procedures – A procedure is used to define and run those factors
- **Cr** = Critical Factors – Important factors that determines the outcome
- Show total time as Value Add and Non Value Add (NVA) percentages for the entire process

Developing an As-Is Business Process Model

- Assign correct flowchart symbols to each step
- Review process flow
- Add any missing steps you identify in the review/validation
- Reorder steps if needed
- Show the flow of activity between steps with arrows
- Show shared responsibility for a step with circles and lines
- Notate any important information

# 6













## Analyze, Evaluate and Submit for Approval

page 35 in the BPM Guide

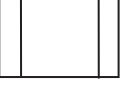
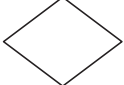
- Are the symbols consistently used correctly?
- Are process steps clearly described?
- Have you labeled your flow and provided a key?
- Does every path take you either back to or ahead to another step?
- Does the chart accurately depict what really happens?
- Have you labeled your flow and provided a key?



## GRAPHICAL NOTATION SYMBOLS

Symbol	Name	Definition	Page 25
	Events	An event either kicks off a process flow, or happens during a process flow, or ends a process flow	
	Connector	On/Off page connectors notate complex overlapping connector lines or continue a process on another page. Label Connectors with UPPERCASE letters	
	Sequence Flow	Used to illustrate the different actions that can occur during a process	
	Association	Used to illustrate association lines to and from data objects and processes	
	Message Flow	Used to attach a data object to a Sequence or Message flow	
	Manual Task	A manual task (work that an organization performs which is done manually); a task can be atomic or non-atomic (compound)	
	System Task	A system task (work that an organization performs which is done by a system or application – not manual); a task can be atomic or non-atomic (compound)	
	Batch Process	Represents the execution of a series of programs ("jobs") on a computer without manual intervention	
	Gateway	Shows a decision point, such as yes/no. Each path emerging from the diamond is labeled with one of the possible answers	
	Interface	Data conversion from one electronic system to another	
	Input Documents	A paper document (or email) that is used for entering data in the process. For electronic data the Interface symbol will be used	
	Output Documentation	An electronic document that is created by the process and can be printed (e.g. reports)	
	Group	Groups are used to highlight certain sections of a diagram without adding additional constraints for performance, as a Sub-Process would	
	Swimlanes - Pool	Pools represent participants in an interactive Business to Business (B2B) Business Process Diagram	
	Swimlanes - Lane	Lanes represent sub-partitions for the objects within a Pool	

# How Much Detail Should You Model

page 18 in the BPM Guide



BPM is often done at various levels of detail. Offering different levels accommodates all forms of audiences and their specific needs. BPM helps divide complex business processes into smaller, less complex sub processes. BPM makes it easier to understand the business process and achieve the desired outcome.

<p><b>Level 1 Business Process</b></p>	<p>This level can be viewed as the aggregation of the complex process referring to the functionality of the organization. This can be taken as the major objective of the business organization, which subsequently gets broken down into sub objectives taken by different departments. As the functions in the organization get divided into the subsequent levels of granularity, similarly the business process also gets divided among various levels of organization granularity as sub-processes.</p>
<p><b>Level 2 Major Processes</b></p>	<p>This level represents a group of processes which belong to a similar area of authority and responsibility but deal with different major aspects of the major business process that resides on the level 1 of business process granularity.</p>
<p><b>Level 3 Business Sub Process</b></p>	<p>This level represents various variants of the business process known as sub-processes which aim at the same business objective but perform a different task in order to achieve the objective. These business sub-processes are further decomposed into activities.</p>
<p><b>Level 4 Business Process Activities</b></p>	<p>An activity can be defined as the smallest part of the business process which is performed by the specialized employees and this activity is related to basic business functions. These activities are performed by employees who are hired by the organization for their specialized knowledge and skills.</p>

## Granularity

### Modeling Levels of Detail

- *High Granularity* (using collapsed sub-processes) – Depicts a coarse level of the process (not much detail), which is usually good for project managers and high-level management
- *Fine Granularity* (using expanded sub-processes) – Depicts the details of the process, which is useful for analysts, developers, testers, architects, etc.

# Final Thoughts

## KNOW WHEN TO STOP MODELING

page 28 in the BPM Guide

It is not necessary to model every detail of the As-Is business process. The trick is to stop at the level where the workflow is generally accurate, and you can answer the following questions:

- Do you understand the root cause of the problems?
- Do you understand why the process behaves the way it does?
- Are you beginning to get irrelevant detail in the model?

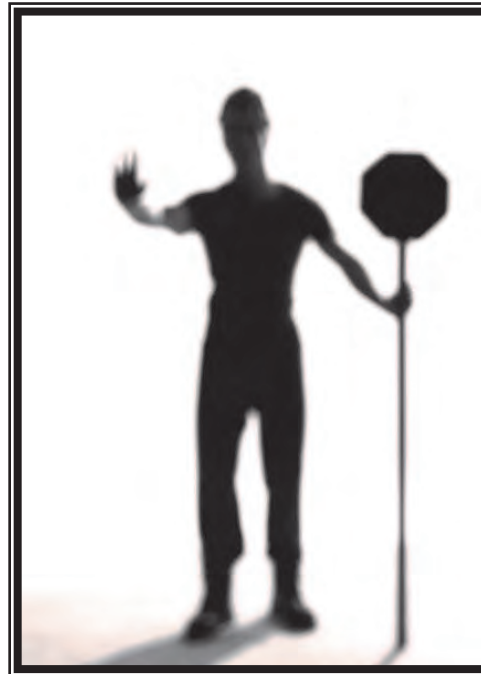

## WANT TO LEARN MORE? THEN DIVE DEEPER

For those that want to dive deeper into the world of BPM, review the in-depth BPM Readiness Guide as it compliments this Quick Start Guide. Both of these documents are resources for State of California departments who want to understand and put into practice a standardized BPM methodology to identify and document existing processes.

**As you repeat the process of modeling, you will get better at it, and gain a deeper understanding of the methods and benefits of process modeling.**

## REALLY, THAT'S IT! YOU ARE READY TO GO FOR IT.

Allow this Quick Start Guide to get you and your organization moving in the BPM direction. You can do it! Look at your business processes.

- What needs documenting?
- What needs improving?
- What can you do better or faster?
- How can you better serve your customers?
- How can team members better understand the business?
- How can your organization be the best?



**All of these questions can be addressed and resolved using BPM.**

## Governance and Controls

### Escalations, Principals & Committees

#### Define Guiding Principles:

Departments need to define their Guiding Principles in order to effectively evaluate options and make judgments in the best long term interest of the organization.

#### Establish Executive Steering Committee:

A steering committee is a body within an enterprise whose purpose is to make strategic decisions concerning enterprise projects. Its members are the Executives of all business areas that are impacted by the project.

#### Escalation and Decision Making:

Establish a formalized escalation process that drives decision-making down to the lowest appropriate level. Recommendations from the lowest level are sent to the Executive Steering Committee for a final decision.



Version 1.0

Skip Campbell  
Chad Crowe  
David Derks  
Gary Dias

Bruce Henry  
Kamal Kathyal  
Brian Kentera

Catherine Lanzaro  
Jesse Mann  
Harriet Miller

Danial Peck  
Hence Phillips  
John Roussel

The Information Technology Leadership Academy is a year-long program for state IT managers with a focus on developing leadership skills. Participants in the academy are selected candidates from state agencies and departments that work in information technology programs. Individuals with a vision for enterprise-wide thinking, strong potential for career advancement, and experience carrying out their organization's mission and vision are ideal candidates for acceptance into this program.